

Advanced Enviro-Septic™ (AES) Treatment System

Vermont Design and Installation Manual



The Public Health
and Safety Company™

SPD & CTD Models
Certified to NSF/ANSI
Standard 40, Class I *
*See Inside Covers for details



Made in USA

✓ Minimizes the Expense ✓ Protects the Environment ✓ Preserves the Site



Presby Environmental, Inc.
The Next Generation of Wastewater Treatment Technology

143 Airport Rd., Whitefield, NH 03598
Tel: 800-473-5298 Fax: (603) 837-9864
Email: info@presbyeco.com

www.PresbyEnvironmental.com

© Copyright July 2010 Presby Environmental, Inc. All rights reserved.

November 2010 Edition

The information in this manual is subject to change without notice. We recommend that you check your state's page on our website on a regular basis for updated information. Your suggestions and comments are welcome. Please contact us at:

Presby Environmental, Inc.
143 Airport Road
Whitefield, NH 03598
Phone: 1-800-473-5298 Fax: (603) 837-9864
Website: www.PresbyEnvironmental.com

Advanced Enviro-Septic™ U.S. Patent Nos. 6,461,078; 5,954,451; 5,606,786; 6,899,359; 6,792,977 and 7,270,532 with other patents pending. Canadian Patent Nos. 2,300,535; 2,185,087; 2,187,126 with other patents pending.

Enviro-Septic® is a registered trademark of Presby Environmental, Inc.
Advanced Enviro-Septic™ is a trademark of Presby Environmental Inc. (registration pending)
© 2010 Presby Environmental, Inc. All rights reserved



**NSF Standard 40 Class I Certified
Advanced Enviro-Septic™ Systems**
Certificate No. 3U460-0
Issued 09/22/09

***Please Note:** Advanced Enviro-Septic™ pipe from Presby Environmental is utilized in both NSF Standard 40 Models and in site-specific designs as allowed by State and/or Local approving authorities. NSF-40 testing of AES confirms effluent treatment and system reliability; however, State and/or Local regulations govern infiltration design considerations. The virtually unlimited design options of AES pipe made it impractical to submit all possible system configurations to NSF-40 testing protocols for Certification. The summary on the back inside cover of this Manual highlights the major differences between NSF-40 Certified Models constructed with AES pipe and AES Systems designed in accordance with State and/or Local regulations for a specific site.*

IMPORTANT NOTICE: This Manual is intended ONLY for use in designing and installing Presby Environmental's Advanced Enviro-Septic™ and Enviro-Septic® Wastewater Treatment Systems.

The use of this Manual with any other product is prohibited.

The processes and design criteria contained herein are based solely on our experience with and testing of Enviro-Septic® and Advanced Enviro-Septic™. Substitution of any other large diameter gravelless pipe will result in compromised treatment of wastewater and other adverse effects.

**Advanced Enviro-Septic™ U.S. Patent Nos. 6,461,078; 5,954,451; 5,606,786; 6,899,359; 6,792,977 and 7,270,532 with other patents pending.
Canadian Patent Nos. 2,300,535; 2,185,087; 2,187,126 with other patents pending.**

State of Vermont
Department of Environmental Conservation
Wastewater Management Division
103 South Main St – The Sewing Bldg
Waterbury VT 05671-0405
www.anr.state.vt.us/dec/ww/wwmd.cfm

[phone] 802-241-3822
[fax] 802-241-2596

Agency of Natural Resources

Innovative/Alternative System Approval
General Use per §1-1001 of the
Wastewater System and Potable Water Supply Rules, September 29, 2007

#2004-02- (2010 approval for Advanced Enviro-Septic Pipe)

Vendor Information

Presby Environmental, Inc.
143 Airport Road
Whitefield, NH 03598

Technology Name

Advanced Enviro-Septic™ and
Enviro-Septic® Leaching System

Contact

David W. Presby, President
Presby Environmental, Inc.
143 Airport Road
Whitefield, NH 03598
Phone (800) 473-5298
Fax (603) 837-9864
Web: www.PresbyEnvironmental.com

Technology Type

Septic Tank Effluent Treatment &
Distribution System

Expiration Date

December 1, 2012

Approval

The Enviro-Septic® Leaching System may be used as part of a subsurface wastewater disposal system approved under the Wastewater System and Potable Water Supply Rules, effective September 29, 2007 (Rules) under the following conditions:

1. The leaching systems must be designed, installed and operated as described in the Vermont Design and Installation Manual, dated 2010, filed with the Agency of Natural Resources (Agency).
2. This approval is based on treatment only of domestic wastewater of low and moderate strength as specified in §1-915(a)(1)(C) & (D) of the Rules. An Enviro-Septic® Leaching System shall not be used as a filtrate effluent disposal system unless the system incorporates pressure distribution of the filtrate effluent.
3. The system may be used for both new and replacement systems.



4. If the Rules are revised during the term of this approval, this approval shall be revised as needed to conform to the revisions.
5. The Designer shall provide a copy of this approval letter to any landowner who is a prospective purchaser of an Enviro-Septic® Leaching System prior to the sale of the system and prior to the filing of any application for a site-specific approval by the Agency for the purchaser's property. The application filed with the Agency shall include the landowner's written acknowledgement of this approval letter. Prior to any sale of the property or completion of a sales agreement to sell the property, a copy of the site-specific permit shall be provided to the prospective purchaser.
6. The vendor shall submit an annual report to the Agency by April 1 of each year containing the following information for the 12 month period ending December 31 of the previous year:
 - A. The number of permitted systems installed in Vermont.
 - B. The address of each installation.
 - C. The name of the owner at the time of installation and any known change in ownership.
 - D. All known problems or failures, with a brief summary of the cause and remedial measures taken.
7. When a project is subject to the Rules, site-specific permission for the use of this product is required in the form of a Wastewater System – Potable Water Supply Permit.
8. A site-specific permit for the use of this product may be revoked if the system fails to function properly. Revocation of the permit will require that the use of the building be discontinued unless another wastewater disposal system is installed based on prior written approval by the Agency.
9. This approval is not a representation or guarantee of the effectiveness, efficiency or operation of an Enviro-Septic® Leaching System.
10. This approval allows for continued use of the original Enviro-Septic Pipe in accord with the above referenced design manual.

Design and Review Conditions

The following conditions will be used by the Department in reviewing permit applications that include an Advanced Enviro-Septic® Leaching System:

Equipment

- Advanced Enviro-Septic® Leaching System

Design and Application

- The leaching system shall be designed in accordance with the approved Vermont Design and Installation Manual.
- The designer shall assure that the system will properly function in all seasons.
- The designer must assess the ventilation path for the particular application and make any necessary provisions to assure proper flow and control of odor emissions.
- The designer shall include in the design a septic tank effluent filter with easy access for inspection and cleaning.

Installation Inspection

- The leaching system shall be installed accordance with the approved plans and under the instruction and guidance of an installer/inspector trained by the manufacturer.
- The leaching system shall be inspected by a Licensed Class 1 Designer or a Licensed Class B Designer, approved by the Vendor, during installation of the system and installation of any tanks before backfilling, and after backfilling and grading is complete. The inspection shall include checking for levelness of the pipes, and inspecting for damage and proper assembly.
- The Designer shall inspect all transport piping for proper installation and watertightness before backfilling.

Permitting

- The permit shall run with the land.
- A copy of the permit shall be provided to any prospective purchaser prior to the sale.
- Each new owner of the property shall inform the appropriate Regional Environmental Office of the Agency within 30 days of the transfer of the property and include the name and mailing address of the new owner.

Effective

November 30, 2010

by



Roger Thompson, Jr.
Regional Office Program Manager

TABLE OF CONTENTS

	<u>Page</u>
Section A, Overview	1
Section B, Components	4
Section C, Introduction	6
Section D, System Configurations	7
Basic Serial & Butterfly Configurations p. 8	
D-Box Distribution Configuration p. 9	
Combination Serial Configuration p. 10	
Multiple Beds and Unusual Shapes p. 12	
In-Ground Bed Systems p. 16	
Elevated Bed Systems p. 17	
Non-Conventional Configurations p. 19	
Section E, General Design Criteria	22
Section F, Vermont State Specific Information	27
Section G, Design Guide, Sizing Tables & Example	29
Table A, Sizing and Total Pipe Req'd., p. 30	
Table B, Pipe Spacing by Slope/Perc Rate, 1-60 MPI, p. 31	
Table C, System Pipe Length and Width, p. 32	
Table D, VT Minimum System Sand Bed Area, Perc Rates 1-60, p. 33	
Worksheet, p. 36	
Section H, Perc Rates 61-120 Design Guide, Sizing Tables	37
Table E, Maximum System Slope for Perc Rates 61-120, p. 37	
Table F, Total Pipe Req'd. Perc Rates 61-120, p. 38	
Table G, VT Minimum System Sand Bed Area, Perc Rates 61-120, p. 38	
Section I, System Sand and Fill Specifications	41
Section J, Pump Systems	42
Section K, Venting Requirements	44
Section L, Site Selection	49
Section M, Installation Requirements, Component Handling & Site Preparation	50
Section N, System Bacteria Rejuvenation and System Expansion	54
Section O, Operation and Maintenance	55
Glossary	56
Appendix A, System Installation Form	

Advanced Enviro-Septic™ Treatment System

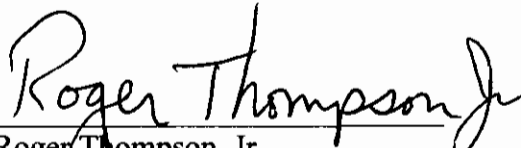
Vermont Design and Installation Manual

Section A, System Overview

Background

Liquid that exits from a septic tank (“effluent”) contains suspended solids that can cause traditional systems to fail prematurely. Solids can overload bacteria, cut off air required for aerobic bacterial activity, and/or seal the underlying soil, interfering with its ability to absorb liquid.

What Our System Does

By utilizing simple yet effective natural processes, the Advanced Enviro-Septic™ Treatment System (AES) treats septic tank effluent in a manner that prevents suspended solids from sealing the underlying soil, increases system aeration, and provides a greater bacterial treatment area (“biomat”) than traditional systems.

Why Our System Excels

The Advanced Enviro-Septic™ Treatment System retains solids in its pipe and provides multiple bacterial surfaces to treat effluent prior to its contact with the soil. The continual cycling of effluent (the rising and falling of liquid inside the pipe) enhances bacterial growth. No other passive wastewater treatment system design offers this functionality. Our systems excel because they are more efficient, last longer, and have a minimal environmental impact.

System Advantages

An Advanced Enviro-Septic™ Treatment System:

- costs less than traditional systems
 - eliminates the need for washed stone
 - often requires a smaller area
 - installs more easily and quickly than traditional systems
 - adapts easily to residential and commercial sites of virtually any size
 - adapts well to difficult sites
 - develops a protected receiving surface preventing sealing of the underlying soil
 - blends “septic mounds” into sloping terrain
 - increases system performance and longevity
 - tests environmentally safer than traditional systems
 - recharges groundwater more safely than traditional systems
 - made from recycled plastic
-

Patented Advanced Enviro-Septic™ Technology

The Advanced Enviro-Septic™ (“AES”) pipe is an onsite wastewater treatment system consisting of a patented configuration of ridged, corrugated, perforated plastic pipe with interior skimmer tabs, surrounded by a mat of random plastic fibers and geotextile fabrics. The Advanced Enviro-Septic™ pipes are assembled and installed in a bed of specified System Sand which can either be below the ground or above. The system is designed to simultaneously purify and disperse effluent after primary treatment by a septic tank. The system is completely passive, requiring no electricity, motors, alarms, computers, etc.¹

¹ Advanced Enviro-Septic™ (AES) is the “next generation” of our Enviro-Septic® (ES) technology. The AES product incorporates Bio-Accelerator™, a proprietary enhancement that screens additional solids from effluent, accelerates treatment processes, assures even distribution and provides additional surface area for bacterial activity. The information and requirements contained in this manual apply to both AES and ES Systems.

ADVANCED ENVIRO-SEPTIC™ WASTEWATER TREATMENT SYSTEM

with BIO-ACCELERATOR™

TEN STEPS OF WASTEWATER TREATMENT: ADVANCED ENVIRO-SEPTIC™ TREATS EFFLUENT MORE EFFICIENTLY TO PROVIDE LONGER SYSTEM LIFE AND TO PROTECT THE ENVIRONMENT.

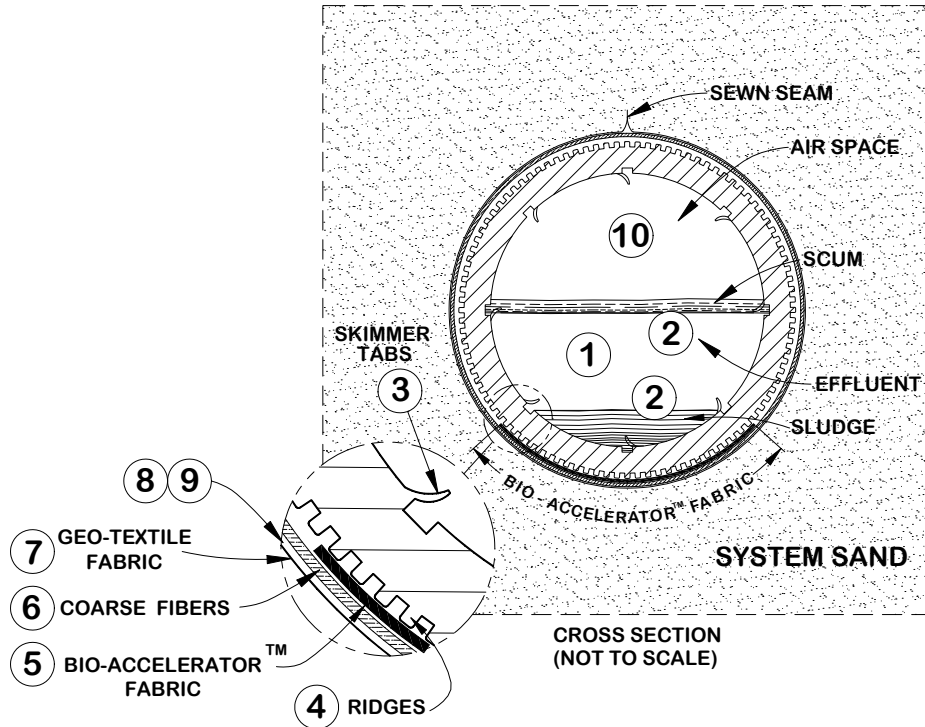

STAGE 1: WARM EFFLUENT ENTERS THE PIPE AND IS COOLED TO GROUND TEMPERATURE.

STAGE 2: SUSPENDED SOLIDS SEPARATE FROM THE COOLED LIQUID EFFLUENT.

STAGE 3: SKIMMERS FURTHER CAPTURE GREASE AND SUSPENDED SOLIDS FROM THE EXITING EFFLUENT.

STAGE 4: PIPE RIDGES ALLOW THE EFFLUENT TO FLOW UNINTERRUPTED AROUND THE CIRCUMFERENCE OF THE PIPE AND AID IN COOLING.

STAGE 5: BIO-ACCELERATOR FABRIC SCREENS ADDITIONAL SOLIDS FROM THE EFFLUENT, ENHANCES AND ACCELERATES TREATMENT, FACILITATES QUICK START-UP AFTER PERIODS OF NON-USE, PROVIDES ADDITIONAL SURFACE AREA FOR BACTERIAL GROWTH, PROMOTES EVEN DISTRIBUTION, AND FURTHER PROTECTS OUTER LAYERS AND THE RECEIVING SURFACES SO THEY REMAIN PERMEABLE.

STAGE 6: A MAT OF COARSE, RANDOMLY-ORIENTED FIBERS SEPARATES MORE SUSPENDED SOLIDS FROM THE EFFLUENT.

STAGE 7: EFFLUENT PASSES INTO THE GEO-TEXTILE FABRICS AND GROWS A PROTECTED BACTERIAL SURFACE.

STAGE 8: SAND WICKS LIQUID FROM THE GEO-TEXTILE FABRICS AND ENABLES AIR TO TRANSFER TO THE BACTERIAL SURFACE.

STAGE 9: THE FABRICS AND FIBERS PROVIDE A LARGE BACTERIAL SURFACE TO BREAK DOWN SOLIDS.

STAGE 10: AN AMPLE AIR SUPPLY AND FLUCTUATING LIQUID LEVELS INCREASE BACTERIAL EFFICIENCY.

System Overview, Continued

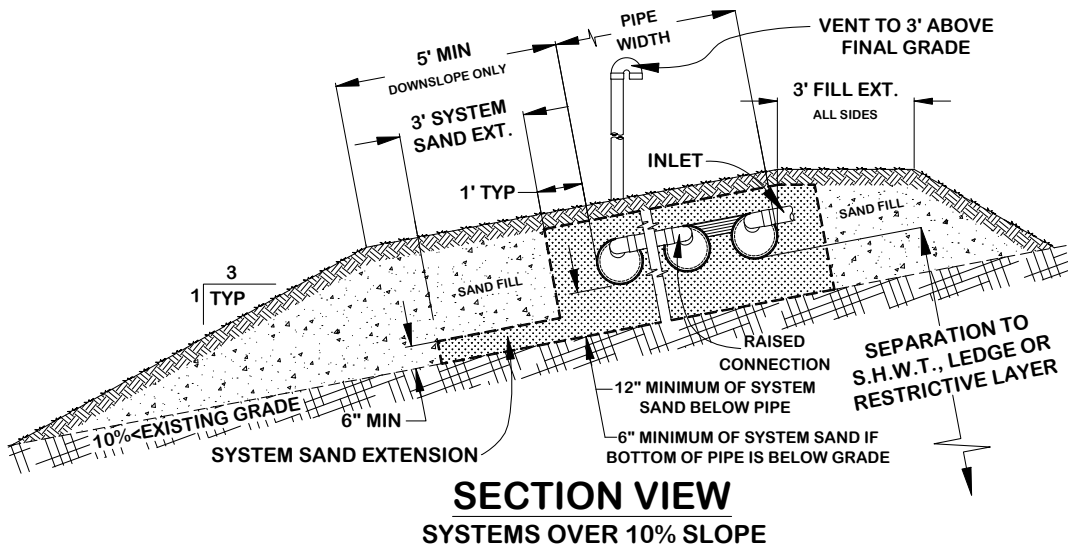
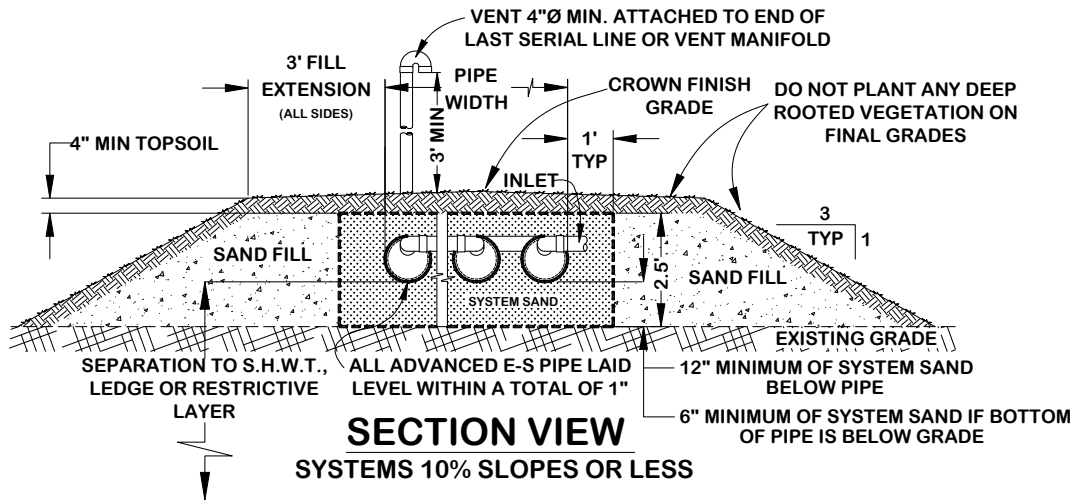
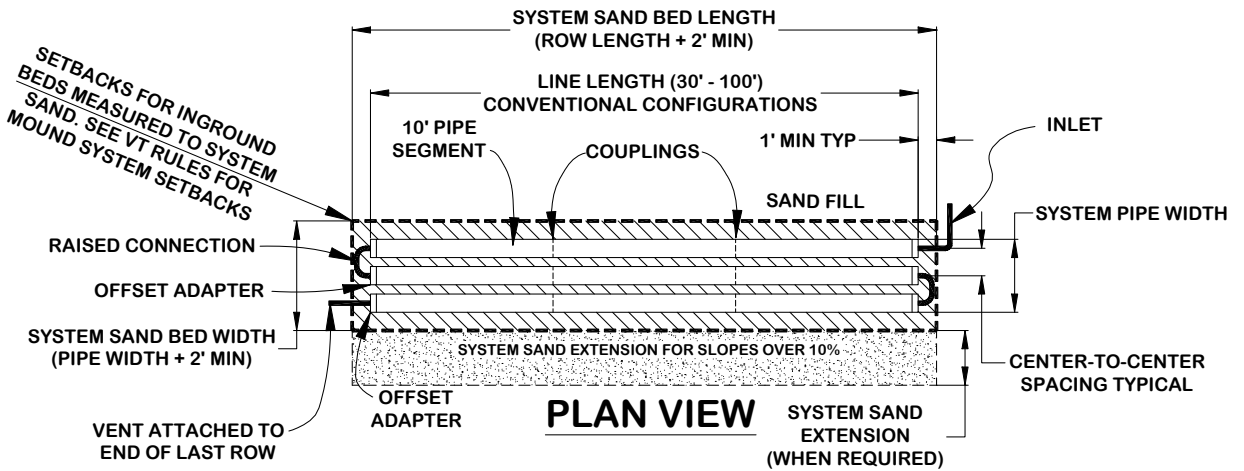

Note: Advance Enviro-Septic™ may be noted as “Advanced E-S” or simply as “AES”

Section B

Advanced Enviro-Septic™ Components

Advanced Enviro-Septic™ Pipe



- Plastic pipe made with a significant percentage of recycled material
- 10 ft. sections (can be cut to any length)
- Ridged and perforated, with skimmer tabs on interior
- Bio-Accelerator™ along bottom of pipe (a tag is sewn into the seam indicating “this side up”).
- Surrounded by a mat of randomly oriented plastic fibers
- Wrapped in a non-woven geo-textile fabric stitched in place
- Exterior diameter of 12 in.
- Each 10 ft. section has a liquid holding capacity of approx. 58 gallons
- Flexible enough to bend up to 90°

Offset Adapter



An offset adapter is a plastic fitting 12 in. in diameter with a 4 in. hole designed to accept a 4 in. inlet pipe, raised connection or vent pipe. The hole is to be in the 12 o'clock position, 7 in. above bottom of pipe. When assembling pipes into rows, note that the geo-textile fabrics do not have to go under offset adapter.

Double Offset Adapter



A double offset adapter is a plastic fitting 12 in. in diameter with two 4 in. holes designed to accept a 4 in. inlet pipe, raised connection, vent or vent manifold, and/or bottom drain, depending upon the particular requirements of the design configuration.

The 4 in. holes are to be aligned in the 12 o'clock and 6 o'clock positions. The holes are positioned 1 in. from the outside edge of the double offset adaptor and 2 in. from each other. When assembling pipes into rows, note that the geo-textile fabrics do not have to go under double offset adapters.

Coupling



A coupling is a plastic fitting used to create a connection between two pieces of Advanced Enviro-Septic™ pipe. Note that the couplings are wide enough to cover 1 or 2 pipe corrugations on each of the two pipe ends being joined. The couplings feature a snap-lock feature that requires no tools. When assembling pipes into rows, note that the geo-textile fabrics do not have to go under couplings. Also note, during installation in cold weather, couplings are easier to work with if stored in a heated location before use.

Raised Straight Connection

A raised straight connection is a PVC Sewer & Drain pipe configuration which is used to connect rows as shown below. The typical application for raised straight connections is when rows are over 100 ft. long.

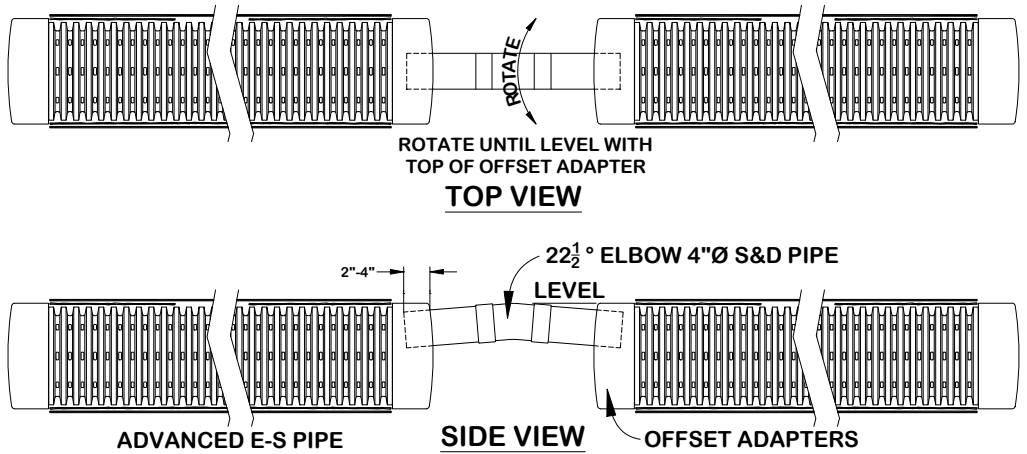

Raised Connection

A raised connection is a PVC Sewer & Drain pipe configuration which is used to connect Advanced Enviro-Septic™ rows as shown below. All PVC joints should be glued.

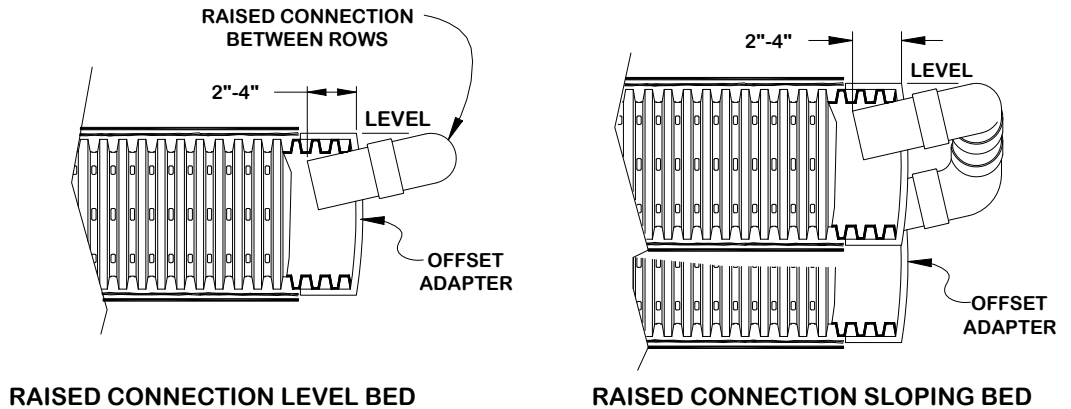

Section C Introduction

Presby Environmental Standards

All Advanced Enviro-Septic™ systems must be designed and installed in compliance with the procedures and specifications described in this Manual and in the product's Vermont approval.

Vermont Rules

This Manual is to be used in conjunction with the State of Vermont Wastewater Management Division "Environmental Protection Rules, Chapter 1, Wastewater System and Potable Water Supply Rules, Effective September 29, 2007. Vermont linear loading requirements must always be honored for all perc. rates.

Conflicts Between Vermont Rules & Manual

In the event of contradictions between this Manual and Vermont Department of Environmental Conservation regulations, Presby Environmental, Inc. should be contacted for technical assistance.

Certification Requirements

Any **newly licensed Vermont** designers and installers who have not previously attended a Presby Environmental, Inc. "Enviro-Septic® Certification Course" are required to obtain certification. Certification is obtained by attending an Advanced Enviro-Septic™ Certification Course presented by Presby Environmental, Inc. or its sanctioned representative. This requirement does not apply to experienced designers and installers who were licensed by the State prior to VT approval of this manual and are familiar with the Enviro-Septic® System.

The State of Vermont and PEI require all designers and installers to be certified. Certification is obtained by attending the "Advanced Enviro-Septic™ Designer and Installer Certification Course" presented by Presby Environmental, Inc. and available at www.PresbyEnvironmental.com.

Special note: Presby Environmental Inc. highly recommends that all individuals involved in the approval, permitting or inspection process also attend a certification course.

Exceptions to Requirements

To resolve any conflicts with or exceptions to any requirements in this Manual, please contact Presby Environmental, Inc.

Technical Support

Presby Environmental, Inc. provides technical support to all individuals using our products. For questions about our products or the information contained in this Manual, or to register for a Certification Course, please contact us at 1-800-473-5298.

Section D System Configurations

Introduction

This section presents the various design configurations of the Advanced Enviro-Septic™ System. The system configuration to be used is determined by:

- Characteristics of the receiving soils
 - Vertical distance to the SHWT or restrictive feature
 - Other characteristics specific to the particular site
 - The daily design flow
-

System Configurations

The following Advanced Enviro-Septic™ System configurations are presented in this Section:

- Basic Serial & Butterfly Distribution (pp. 8-9)
 - D-Box Distribution (Parallel) (p. 9)
 - Combination Serial Distribution (pp.10-11)
 - Multiple Bed & Unusual Shapes (pp.12-15)
 - In-Ground Bed Systems (p.16)
 - Elevated Bed Systems (pp. 17-18)
 - Non-Conventional System Configurations (pp. 19-21)
-

Bed design restrictions – 61-120 percolation rates

- Beds in soils with percolation rates from 61-120 minutes per inch must be designed using basic serial distribution.
 - All systems with percolation rates of 61-120 minutes per inch must be designed as mounds.
-

Basic Serial Distribution

Introduction

Basic Serial distribution may be used for single beds of 900 GPD or less. Basic Serial distribution systems are quick to develop a strong biomat in the first row and provide a longer flow route, providing improved effluent treatment. Basic Serial distribution may be used in all soil types.

Definition

Basic Serial distribution incorporates rows in serial distribution in a single bed.

Note: Basic Serial distribution is installed in a single bed with a series of Advanced Enviro-Septic™ rows connected at the ends with raised connections, using offset adapters or double offset adapters and PVC sewer and drain pipe. One offset adapter is installed at the single inlet, and another offset adapter (or double offset adaptor if needed) is installed at the end of the system.

Flow Equalizers Not Required

Flow equalizers are not required when pumping to a distribution box for a Basic Serial system.

Note: All Advanced Enviro-Septic™ Systems in soils with perc rates 61- 120 MPI are recommended to be designed as long and narrow as possible for the site. Vermont linear loading rate requirements must be honored for all perc. rates. Each bed must contain a minimum of two parallel rows.

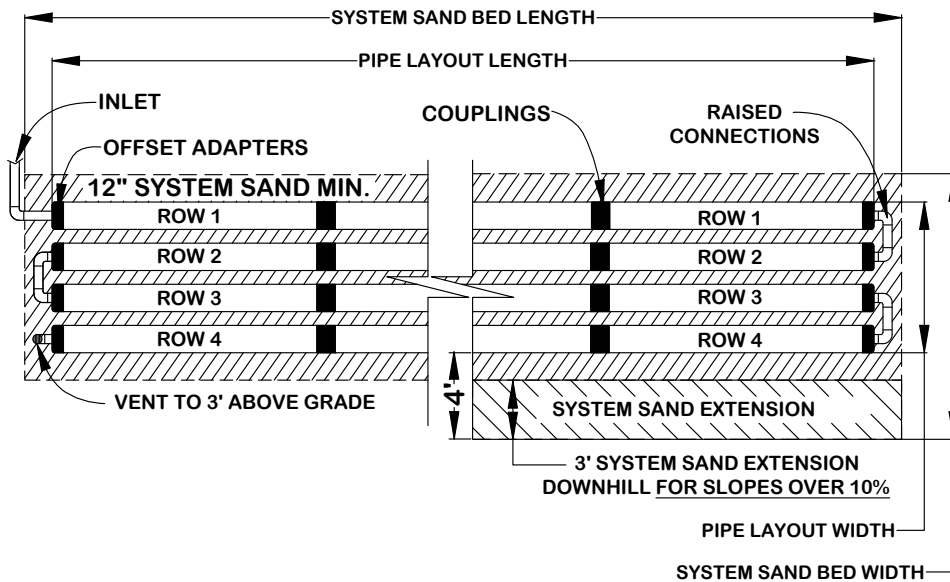

Basic Serial Distribution, continued

Butterfly Configuration

A butterfly configuration, such as the one shown below, is considered to be a single bed system; a minimum 2 ft. separation distance (measured pipe to pipe) is required between the left and right sides provided that the elevation of the two sides is the same or within 1 ft. of the same elevation. Each serial section must contain at least half of the required pipe. In the event of an elevation differential greater than 1 ft., the two sides would be considered separate "beds."

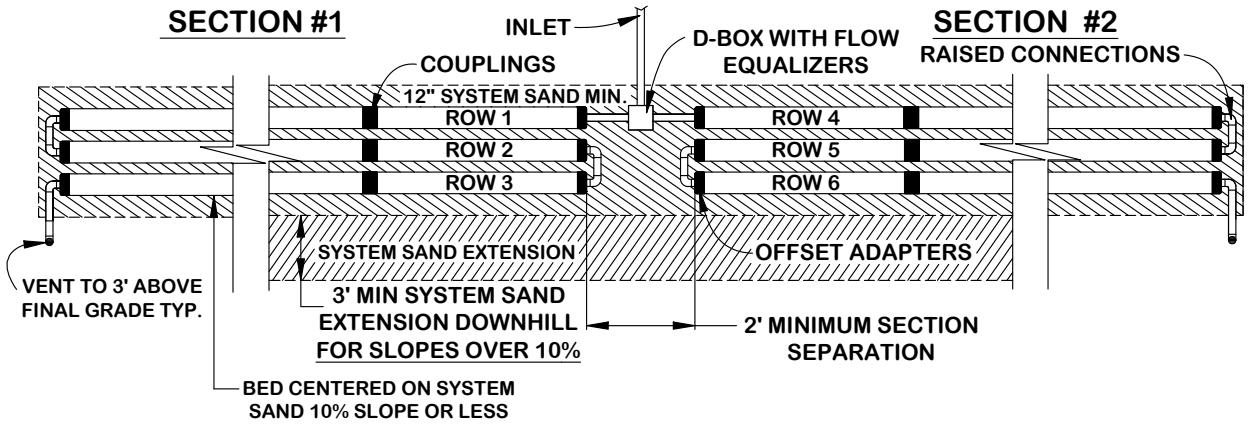

D-Box Distribution Configuration (a.k.a. "Parallel" or "Finger" configuration)

All rows in this configuration must be the same length. Flow equalizers must be used in the D-Box. Manifold the ends of all rows to ensure adequate air and liquid flow through each row. Place the D-box on level, firmly compacted soil. All rows must be laid level. A minimum of a 2 in. drop is required between the D-box outlet and the Advanced Enviro-Septic™ pipe inlets. Manifold to be sloped toward AES pipes.

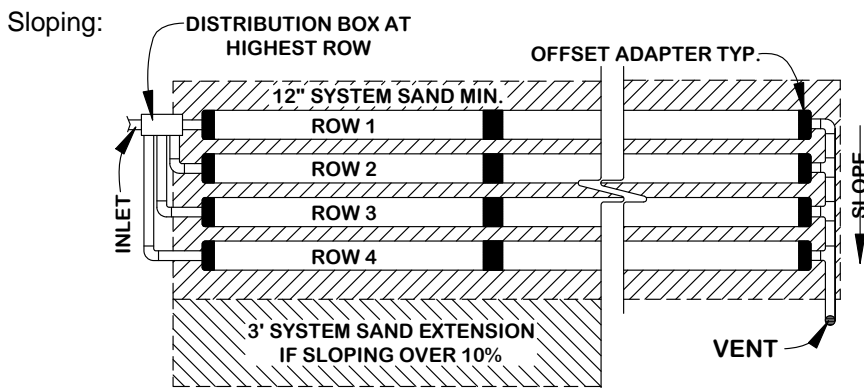
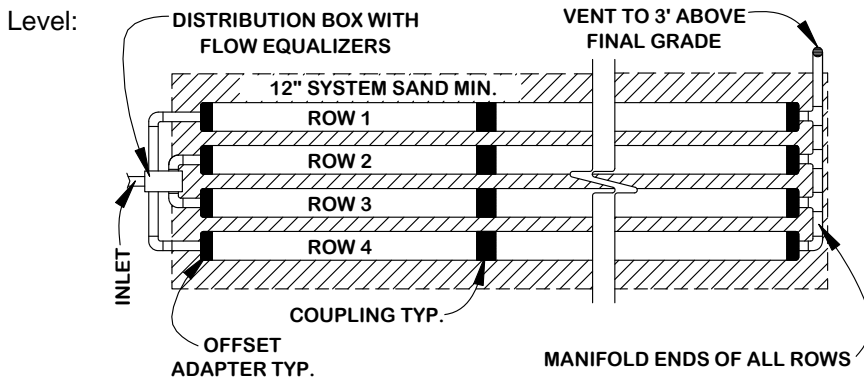

Combination Serial Distribution

Introduction Combination Serial distribution is required for systems with design flows greater than 900 GPD. Combination Serial distribution is quick to develop a strong biomat in the first row of each section, providing improved effluent treatment. The total length of pipe required divided by the total number of sections equals the minimum feet of pipe required for each section.

Definition Combination Serial distribution consists of two or more Basic Serial sections installed in a single bed. Each section of Combination Serial distribution is a series of Advanced Enviro-Septic™ rows connected at the ends with raised connections, using offset adapters and PVC sewer and drain pipe. An offset adapter is installed at each section inlet. An offset adapter or double offset adapter is placed at the end of each section.

Flow Equalizers Required All distribution boxes used to divide effluent flow require flow equalizers in their outlets. Flow equalizers are limited to a maximum of 20 GPM per equalizer.

Section Loading Each section in a Combination Serial system has a maximum daily design flow of 500 GPD. More than the minimum number of sections may be used.

Example: Daily design flow = 1,000 gpd requires $(1,000 \div 500) = 2$ sections min.

- Section Length Requirement**
- Each section must have the same minimum linear feet of pipe.
 - The minimum linear feet of pipe per section is determined by dividing the total linear feet required in the Advanced Enviro-Septic™ system by the number of sections required.
 - A section may exceed the minimum linear length.
 - Rows within a section may vary in length to accommodate site constraints (See Non-Conventional Configurations, pp. 19-21).

Note: All Advanced Enviro-Septic™ Systems in soils with perc rates 61-120 are recommended to be designed as long and narrow as possible for the site. Each bed must contain a minimum of two parallel rows. VT linear loading rates must always be honored for all perc. rates.

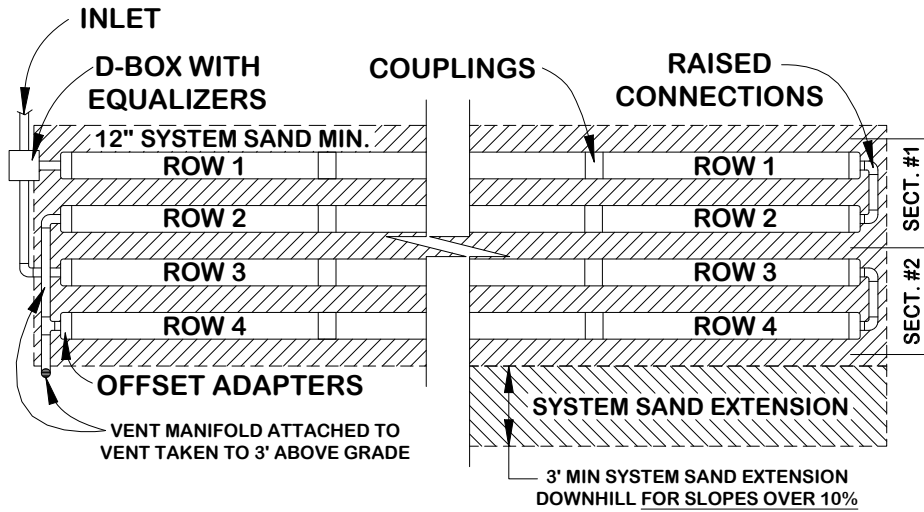

Note: when vent manifold is on the same side as the serial section inlets, the manifold runs over the top of these inlets (as shown above).

Multiple Bed Distribution & Unusual System Shapes

Definition

Multiple Bed distribution incorporates two or more beds, each bed with Basic Serial or Combination Serial distribution, and each receiving an equal amount of effluent from a distribution box. Bed separation is determined by Vermont rules. See "Bed Separation Distances," below.

Flow Equalizers Required

All distribution boxes used to divide effluent flow require flow equalizers in their outlets. Flow equalizers are limited to a maximum of 20 GPM.

Bed Length Requirement

- Each bed must have the same minimum linear feet of pipe.
- The minimum linear feet of pipe per bed is determined by dividing the total linear feet required in the Advanced Enviro-Septic™ System by the number of beds.
- Rows within a bed may vary in length to accommodate site constraints.

Bed Separation Distances

- A 10 ft. separation distance is required by the State of Vermont between multiple beds.
- For in-ground systems, this distance is measured from the closest edges of the System Sand beds.
- For mound systems, the 10 ft. separation distance is measured from toe-of-slope of one bed to nearest toe-of-slope of other bed(s). To accommodate construction access and site constraints, additional separation distance may be necessary.

Butterfly Configuration

A Butterfly Configuration system is considered a single bed system and therefore separation distance between the left and right halves of the system is a minimum of 2 ft. See p. 9, Butterfly Configurations, and detail below.

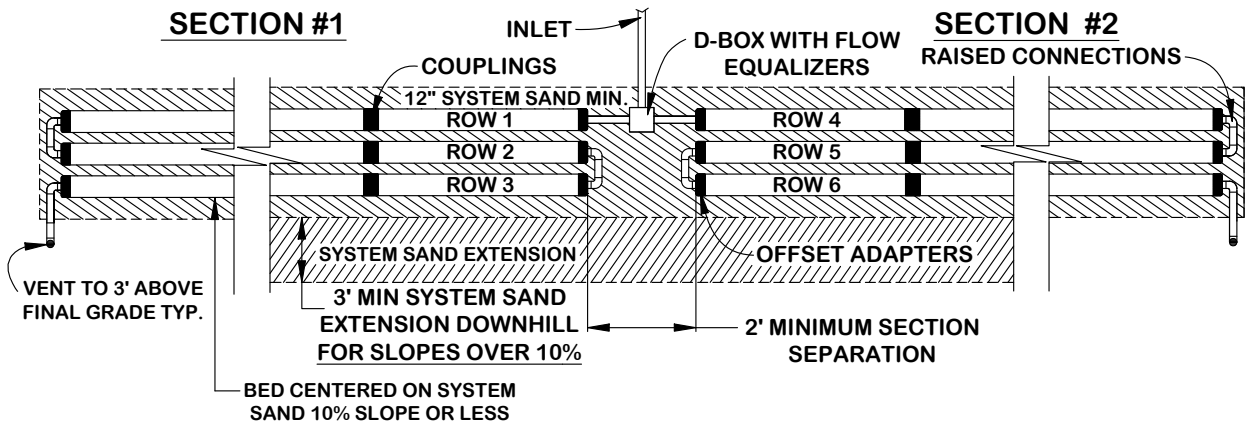

Multiple Bed Orientation

Multiple beds may be oriented along the contour of the site or along the slope of the site. End-to-end configurations are preferred over side-to-side configurations (as shown in detail below).

Note: All Advanced Enviro-Septic™ Systems in soils with perc rates 61-120 MPI are recommended to be designed as long and narrow as possible for the site. Each bed must contain a minimum of two parallel rows. VT linear loading rates must always be honored for all perc. rates.

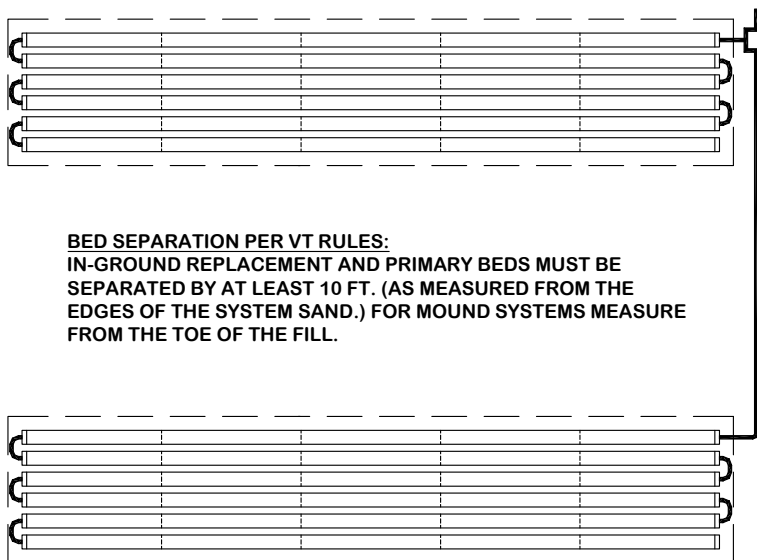

Angles

Angled configurations generally have one or more specific bends, but the rows should follow the contour of the site as illustrated below. Rows are angled by bending pipes (first drawing, below) or through the use of offset adapters (second drawing, below).

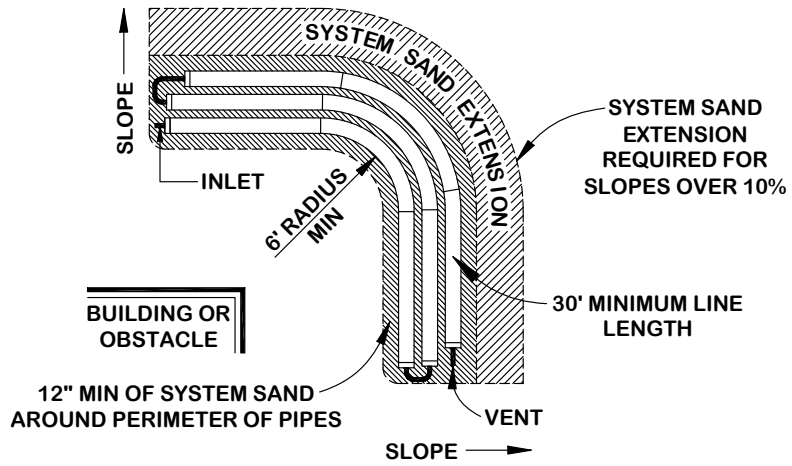

Note: A 10 ft. length of Advanced Enviro-Septic™ pipe may be bent up to 90°.

Note: The angled system shown below requires 30 ft. minimum row lengths.

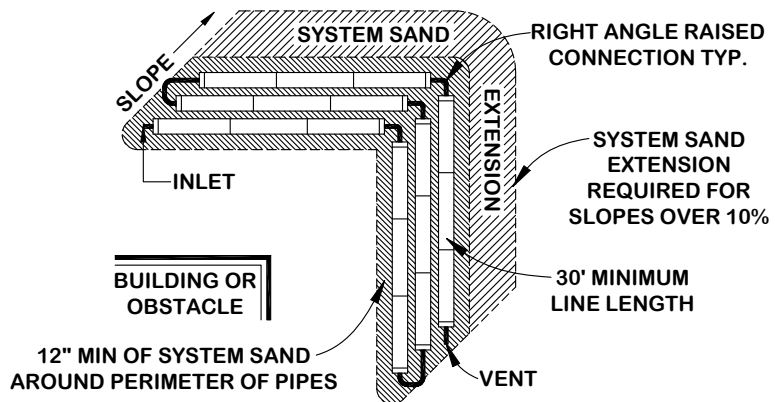

Curves

Curved configurations work well around structures, setbacks, and slopes. Multiple curves can be used within a system to accommodate various contours of the site.

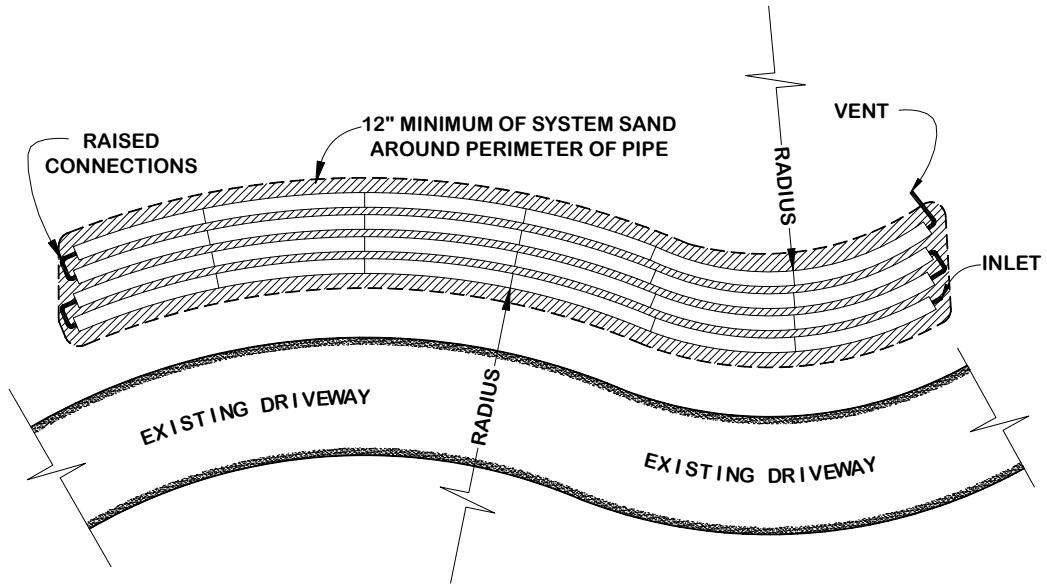

In-Line Beds

In-Line Beds, which are similar to trenches, are used to accommodate site restraints and to meet VT linear loading rates in slower soils. Rows of pipe are connected using Raised Straight Connections. Also see details on p. 40.

- Two rows minimum, all of equal length
- 30 ft. minimum 100 ft. maximum row length
- Three ft. minimum bed width, length per VT linear loading requirements
- Rows centered in System Sand for level beds
- Rows grouped at high contour for sloping beds

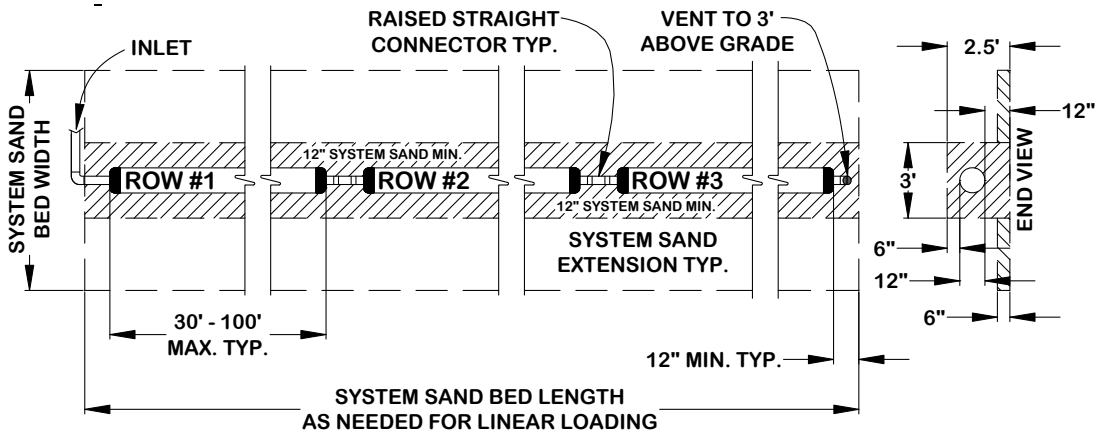

In-Ground Bed Systems

Introduction

Advanced Enviro-Septic™ Systems are installed below existing grade for sites with no soil restrictive features to limit placement.

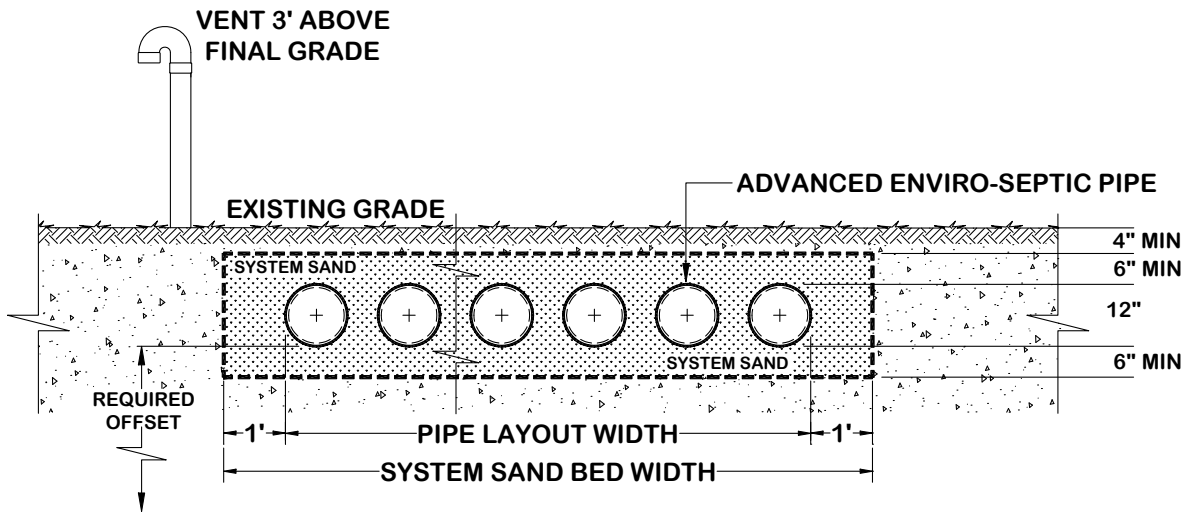

System Slope

In-Ground systems are not allowed to have a sloping bed.

Elevated Bed Systems

Introduction

Elevated Advanced Enviro-Septic™ Systems are designed for sites with soil, depth to ground water or restrictive feature constraints that do not allow for In-Ground Bed Systems. All AES Systems in soils with perc rates 61-120 MPI must be constructed as Elevated Bed ("mound") systems.

Definition

An Elevated bed system is a soil absorption field with any part of the system (including soil cover) above existing grade.

Site Preparation

Refer to Section M, Installation Requirements, Component Handling and Site Preparation, pp. 50-53, for instructions regarding site preparation for Elevated Bed Systems.

Elevated Bed Systems Fill Extensions

Elevated bed systems require 3 ft. fill extensions on each side (measured from the pipe), after which side-slope tapering is to be a maximum of 3 horizontal feet for each 1 foot of vertical drop until it meets existing grade.

Elevated bed sloping 10% or less:

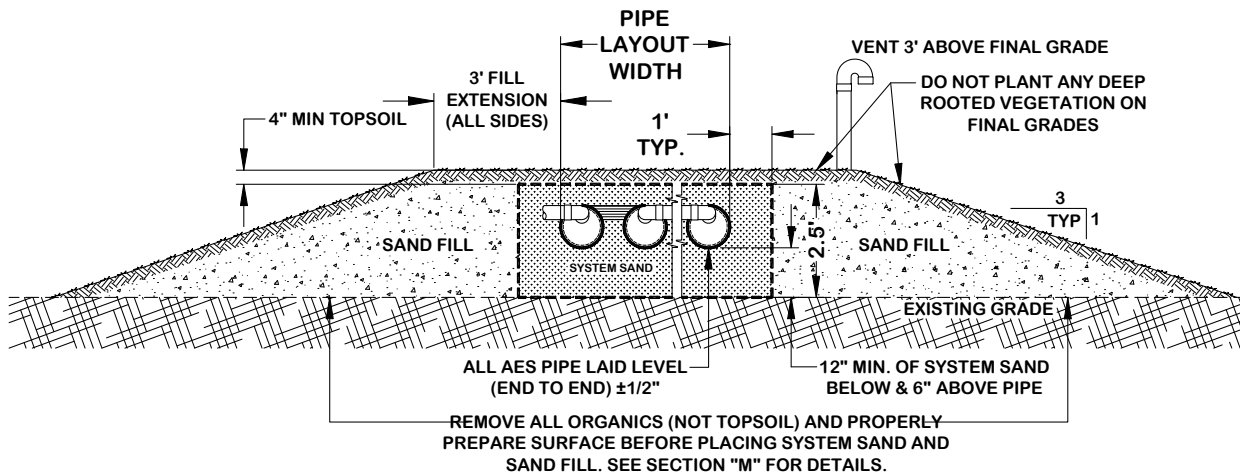

Beds with multiple slopes:

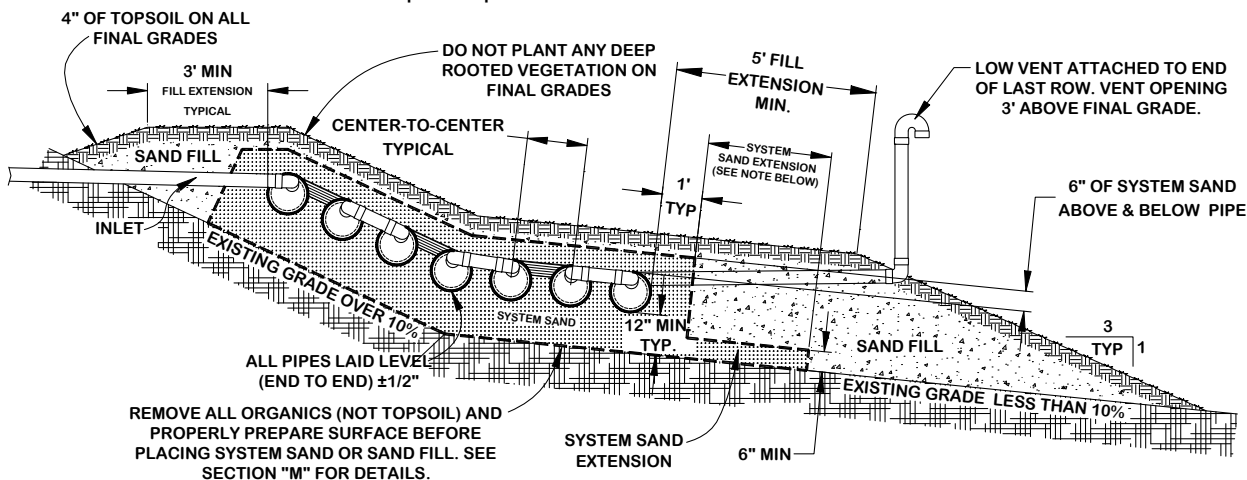

NOTE: 3' SYSTEM SAND EXTENSION REQUIRED IF ANY PORTION OF BED IS OVER 10% SLOPE.

Elevated Bed Sloping over 10%

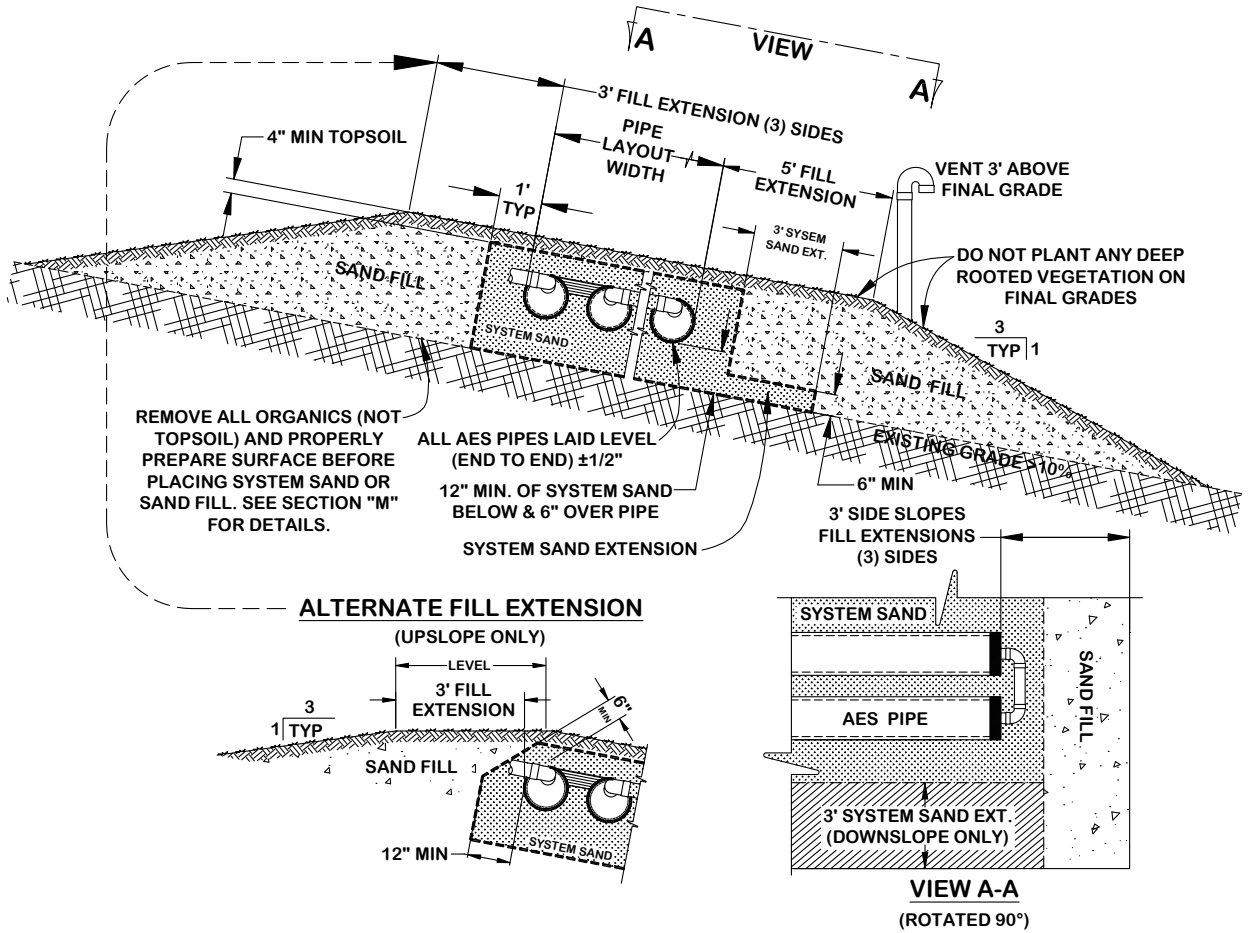

Non-Conventional System Configurations

Introduction

Non-conventional system configurations may have irregular shapes to accommodate site constraints.

Total Linear Feet Requirement

- Each section or bed must have at least the minimum linear feet of pipe (total feet of pipe required divided by number of sections equals the minimum feet required for each section or bed).
- A section or bed may exceed the minimum linear length.
- Rows within a section or bed may vary in length to accommodate site constraints.

Bed Lengths Greater than 100 ft.

The row lengths in the system shown below remain within the maximum limit of 100 ft., but the bed is uncommonly long. Raised straight connections allow these longer bed lengths.

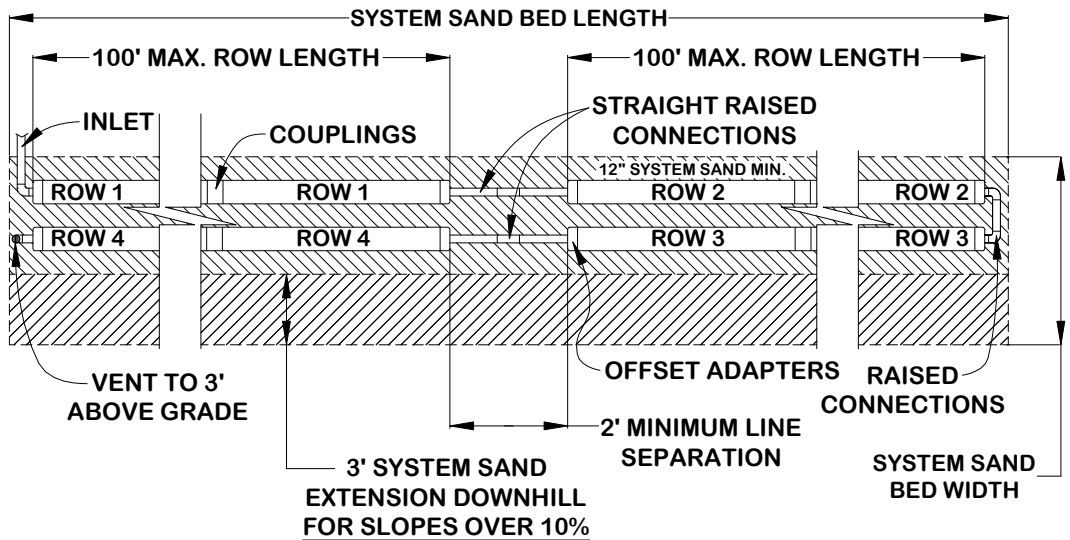

Note: Each row must be of equal length.

Raised Straight Connector

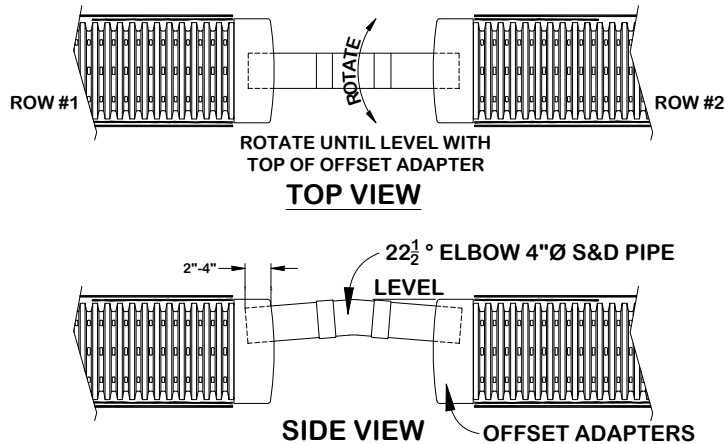

Non-Conventional System Configurations, continued

Trapezoids

This system is trapezoidal to meet horizontal setbacks to site constraints such as buildings, lot lines or surface waters.

Note: System configurations must avoid terrain features that could concentrate surface or ground waters on the down slope side. Shortest row must honor Vermont linear loading rate requirement.

Non-conventional combination system - Trapezoidal

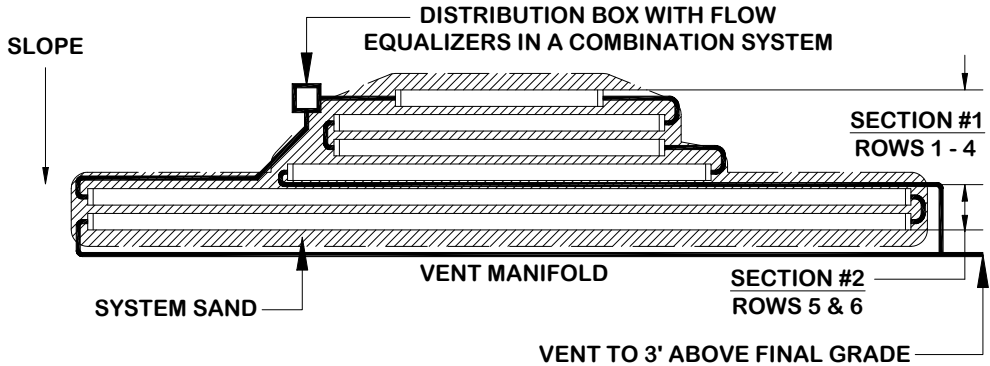

NOTE: SECTIONS #1 AND #2 MUST HAVE AT LEAST THE MINIMUM LINEAR FOOTAGE REQUIRED PER SECTION.

Row Lengths Less than 30 ft.

In general, we recommend that Advanced Enviro-Septic™ rows are from 30 ft. to 100 ft. in length. However, if site constraints require a system design with ANY row shorter than 30 ft., the design must be a D-Box or Combination Serial Configuration. Row lengths less than 30 ft. require a D-box and at least two Serial Sections. If row length is 15 ft. or less a minimum of three Serial Sections are required. All D-Box outlets must have flow equalizers. VT linear loading rates must be honored.

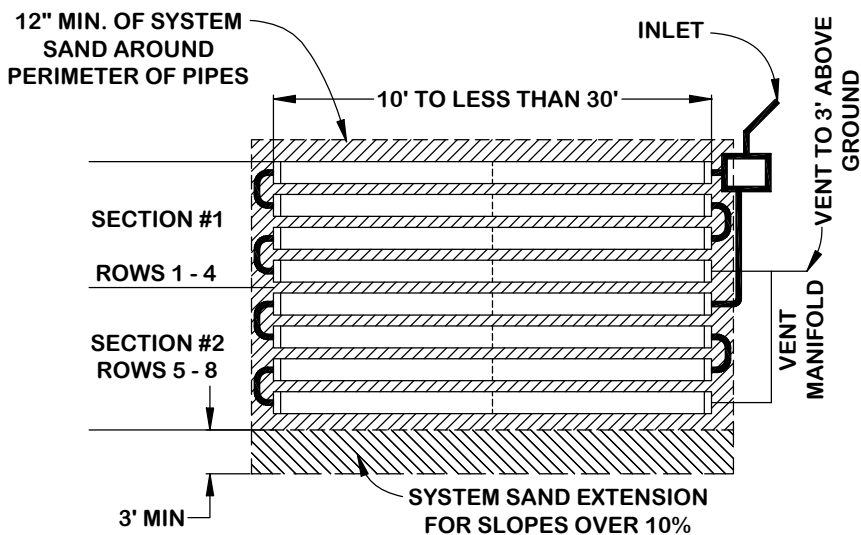

NOTE: A COMBINATION SYSTEM MUST BE USED WHEN LINE LENGTHS ARE LESS THAN 30'.

Non-conventional Basic Serial configuration

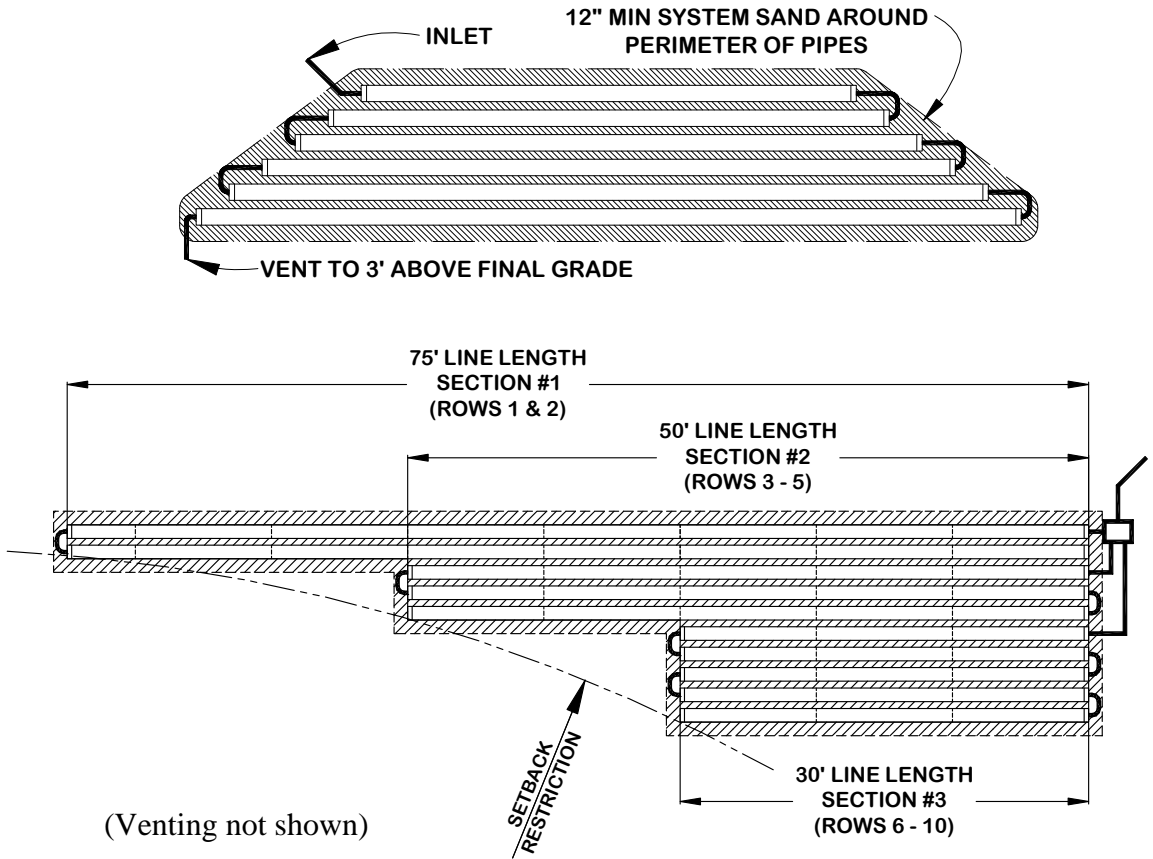

Note: The shortest row length must honor Vermont's linear loading rate. For this illustration, the length used for the calculation would be 30 ft. For example: a (3) bedroom residence at 420 gpd loading would give a linear loading rate of $420 \text{ gpd} \div 30 \text{ ft.} = 14 \text{ gpd per linear foot.}$

Section E General Design Criteria

Converging Flows Restriction

Advanced Enviro-Septic™ Systems must not be located where surface or ground waters will converge, causing surface water flow to become concentrated or restricted within the soil absorption field.

Distribution Box Manifold

If a D-box manifold is utilized, velocity reduction of the effluent entering the D-box is suggested. This configuration is especially useful when designing for large quantity daily design flows. See "Velocity Reduction," this Section, p. 26.

DISTRIBUTION BOX MANIFOLD (TO EVENLY DIVIDE FLOW)

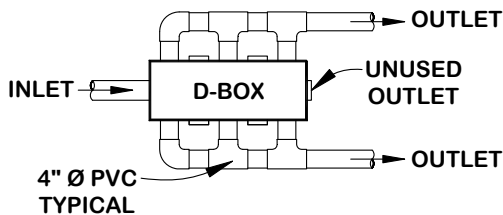

NOTE: UTILIZING EVERY OTHER OUTLET WILL PROVIDE ROOM FOR REQUIRED PIPING AND ALLOW FOR EASIER INSTALLATION

End-to-End Preferred Over Side-to-side

If site conditions permit, end-to-end configurations are preferable to side-to-side configurations.

Filters & Baffles

- **Charcoal filters in vent stacks (for odor) are not recommended by PEI.**
 - Effluent filters **must** be maintained on at least an annual basis. Follow manufacturer's instructions regarding required inspections, cleaning and maintenance of the effluent filter.
 - Filters must allow the free passage of air to ensure the proper functioning of the system. A blocked filter in any on-site septic system could interfere with venting, causing the system to convert to an anaerobic state.
 - All septic tanks must be equipped with baffles to prevent excess solids from entering the Advanced Enviro-Septic™ System.
-

Garbage Disposals (a.k.a. Garbage Grinders)

No additional Advanced Enviro-Septic™ pipe is required when using a garbage disposal (grinder). If a garbage disposal is utilized, follow the State's requirements regarding septic tank sizing. Multiple compartment septic tanks or multiple tanks are preferred and should be pumped as needed.

General Design Criteria, continued

Horizontal Separation Distances	Horizontal separation distances are measured from the outer perimeter of the System Sand for below grade fields and in accordance with VT rules for mound systems.
Row Elevations	For sloping sites, elevations must be provided on the construction drawing for each Advanced Enviro-Septic™ row in the bed system.
Row Orientation	Advanced Enviro-Septic™ rows must be laid level to within +/- ½ in. and preferably should be parallel to the contour of the site. The center-to-center spacing tolerance is +/- 2 in.
Row Requirement	All beds must have at least 2 parallel rows. Rows may be configured in a linear manner and connected by raised connections. VT linear load rates must always be honored.
Long, Narrow AES Systems Recommended Perc Rates 61-120 MPI	All Advanced Enviro-Septic™ Systems in soils with perc rates 61-120 MPI are recommended to be designed and installed as long and narrow as possible for the site. Long, narrow configurations provide the optimal liquid distribution conditions. VT linear loading rates must always be honored.
Maximum and Minimum Row Lengths	To maintain efficient effluent cycling within the Advanced Enviro-Septic™ pipe, the maximum row length is 100 ft. and the minimum row length is 30 ft. (For acceptable exceptions to this rule, refer to Section D, Non-Conventional System Configurations, pp. 19-21.) VT linear loading rates must always be honored.
Pump System Requirements	<ul style="list-style-type: none">• The use of pressure distribution with the Advanced Enviro-Septic™ System is <u>not</u> permitted.• Pump systems to gain elevation are allowed with the Advanced Enviro-Septic™ System.• Systems incorporating pumps to gain elevation must use differential venting and velocity reduction to control liquid flow.

Reference: See Section J, Pump System Requirements, p. 42.

Replacement Field – Mound Systems Only

In the event of system malfunction, contact PEI for technical assistance prior to attempting Rejuvenation procedures. Refer to Section N, System Bacteria Rejuvenation and Expansion, p. 54. In the unlikely event that an Advanced Enviro-Septic™ System needs to be replaced ...

- It can be reinstalled in the same location, eliminating the need for a replacement field reserve area if allowed by state and local authorities.
- All unsuitable material must be removed prior to replacement system construction.
- Disposal of hazardous materials to be in accordance with state and local requirements.
- Contact the appropriate local or state department for necessary permits.

Note: Below grade systems must be replaced in accordance with Vermont rules and may require the replacement system to be located in the reserve area.

Vertical Separation Distances

Vertical separation distance from SHWT or restrictive features is measured from the bottom of the Advanced Enviro-Septic™ pipe.

Septic Tank and Distribution Box Elevations

The outlet of a septic tank or distribution box must be set at least 2 in. above the highest inlet of the Advanced Enviro-Septic™ row, with the connecting pipe slope not less than 1% (approximately 1/8 in. per foot.)

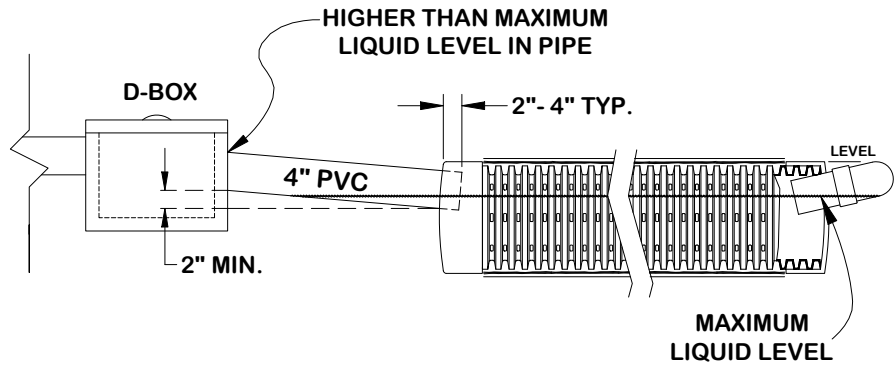

Sloping Sites

- The percentage of slope in all system drawings refers to the slope of the Advanced Enviro-Septic™ System, not the existing terrain.
 - The system slope and the site slope do not have to be the same.
 - Maximum site slope is 33% and maximum system slope is 20%; permissible slope varies depending on the soil's perc rate.
 - Center-to-center spacing of the pipes varies depending on the system slope; refer to Table B, p. 31.
 - The slope of the site and/or the system may contain more than one slope provided the maximum allowed slope is not exceeded.
-

System Sand Bed Dimension Specifications

The height of an Advanced Enviro-Septic™ System measures 24 in. minimum for below grade fields and 30 in. minimum for above grade fields (not including cover material):

- 6 in. minimum of System Sand below the Advanced Enviro-Septic™ pipe for **below grade/in ground fields**
- 12 in. minimum of System Sand below the Advance Enviro-Septic™ pipe for **above grade/elevated fields**;
- 12 in. diameter of the Advanced Enviro-Septic™ pipe; and
- 6 in. minimum of System Sand above the Advanced Enviro-Septic™ pipe.

The System Sand Extension area (required in systems sloping over 10%) is required to be a minimum of 6 in. deep. (See drawings on pp. 17-18.)

System beds may be located as deep as 3 feet below final grade (from the bottom of the Advanced Enviro-Septic™ pipe to the final grade).

Note: No barrier materials (hay, straw, tarps, etc.) are to be placed between the System Sand and cover material; such materials may cut off necessary oxygen supply to the system.

General Design Criteria, continued

System Sand Specifications	It is critical to the proper functioning of the Advanced Enviro-Septic™ System that the proper amount and type of System Sand be installed. “System Sand” should meet the requirements of § 1-913(c)(2) (Vermont Rules), which is ASTM C-33, with not more than 2% passing a #200 sieve. Refer to Section I, System Sand and Fill Material Specifications, p. 41.
System Side Slopes	Side slope tapering is to be a maximum of 3:1; steeper side slope tapering requires a state waiver.
Ten Foot Increments Work Best	It is easier if row lengths are designed in exact 10 ft. increments since Advanced Enviro-Septic™ pipe comes in 10 ft. sections. However, if necessary, the pipe is easily cut to any length to meet site constraints. Using 5 ft. increments minimizes waste of pipe material.
Topographic Position Requirement	The topographic position of the site must be convex, hill slope, or flat. No onsite system may be located on concave slopes that concentrate surface flows unless upslope terrain is sufficiently altered to redirect surface flows away from the system.
Velocity Reduction	Reduce the velocity of liquid entering Advanced Enviro-Septic™ pipe to remove turbulent flow. A distribution box with a baffle or inlet tee may be adequate for velocity reduction in most systems. When pumping to gain elevation, pump to an oversized distribution box or equivalent with proper baffles or tee at the end of the delivery line.
Venting Requirements	Venting is required for all Advanced Enviro-Septic™ Systems. <u>Reference:</u> See Section K, Venting Requirements, pp. 44.
Wastewater Strength	<ul style="list-style-type: none">• Where wastewater strength is high, additional Advanced Enviro-Septic™ pipe is recommended. Presby Environmental, Inc. provides technical support to all individuals using our products. For questions regarding design considerations when treating high strength wastewater, please contact us at 1-800-473-5298.
Water Purification Systems	<ul style="list-style-type: none">• Water purification systems and water softeners should not discharge into an Advanced Enviro-Septic™ System. This “backwash” does not require treatment and the additional flow may overload the system.• Consult with your designer and/or installer for alternative means of dispersal.• If there is no alternative means of disposing of this backwash other than in the AES System, then the system will need to be “oversized.” Calculate the total amount of backwash in GPD, multiply by 3, and add this amount to the daily design flow when determining the field and septic tank sizing.• Water purification systems and water softeners require regular routine maintenance; consult and follow the manufacturer’s maintenance recommendations.

Section F Vermont State Specific Information

Certification Requirements

See "Certification Requirements," Section C, p. 6.

Perc Rate Limitations

Advanced Enviro-Septic™ Systems may be used in soils with perc rates from 1 to 120 MPI.

Limitations in soils with perc rates of 61 – 120 MPI:

- Systems must be designed using basic serial distribution.
 - Systems must be designed as elevated bed (mound) systems.
 - Multiple beds are common in these soils. No bed in a multiple bed system can have a daily design flow greater than 500 gpd. Separate multiple beds in accordance with Vermont rules.
-

Design Flow

Residential design flow for the Advanced Enviro-Septic™ System is calculated in accordance with Vermont rules. Systems servicing more than two residences shall use the Commercial portions of Table A and Table D.

- The **minimum** daily design flow for any single-family residential system on its own lot is two bedrooms and 300 GPD for any commercial system.
 - Certain fixtures, such as jetted tubs, may require an increase in the size of the septic tank.
 - Daily design flow for a single bedroom apartment with a kitchen connected to a residence (also sometimes referred to as a "studio" or "in-law apartment") shall be calculated by adding two additional bedrooms (280 GPD).
 - When daily design flow is determined by water meter use for commercial systems, refer to Vermont Rules, Section 1-808.
 - PEI recommends take the average daily use from a peak month and multiply it by a peaking factor of 2 to 3 times.
 - Note that "daily design flows" are calculated to assume occasional "peak" usage and a factor of safety; Systems are not expected to receive continuous dosing at full daily design load.
-

Design Restriction over 900 GPD

Systems in Vermont with a daily design flow greater than 900 GPD ("high flow systems") are required to be designed as Distribution Box, Combination or Multiple Bed configurations.

Design Restriction in all Soils

Vermont linear loading rates must always be honored.

Exceptions require waiver

Exceptions to any Vermont rules other than those specifically discussed in this Manual require a DEC waiver. Please contact us for technical assistance at (800) 473-5298.

Vermont State Specific Information, continued

Section Loading Limit Each Combination Serial section is limited to a maximum daily design flow of 500 GPD.

Pressure Distribution The use of pressure distribution lines in Advanced Enviro-Septic™ Systems is **prohibited**. Pumps may be utilized when necessary only to gain elevation and to feed a distribution box which then distributes effluent by gravity to the AES System.

Raised Systems Fill Extensions

- Raised systems that slope 10% or less require 3' extensions on each side (including System Sand and sand fill) before tapering.

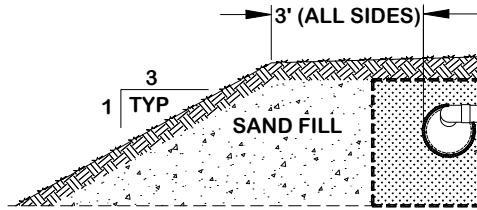

- Sloping systems that slope greater than 10% require 3' extensions on three sides and 5' on the down slope side before tapering.

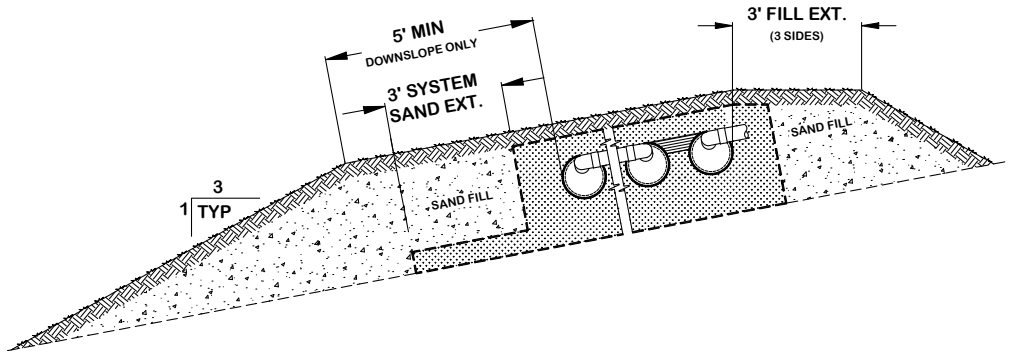

- Tapering is to be 3 horizontal feet for each 1 foot of vertical drop.
- Refer to Section M, pp. 50-53 for erosion control and surface water diversion procedures.

Setbacks (Horizontal) Horizontal setbacks are measured from the outer perimeter of the System Sand. Elevated bed (mound) system setbacks are measured according to Vermont Rules

System Sand Specifications It is **critical** to the proper functioning of the Advanced Enviro-Septic™ System that the proper amount and type of System Sand be installed. "System Sand" must meet the requirements of Vermont rule §1-913(c)(2) with not more than 2% passing the #200 sieve. Refer to Section I, System Sand and Fill Material Specifications, p. 41.

Venting Requirements **Venting is required for all Advanced Enviro-Septic™ Systems.** See Section K, "Venting Requirements," pp. 44-48.

Vertical Separation Distances

- Required minimum vertical separation distance to seasonal high water table (SHWT) is 36 in. and 48" to ledge/bedrock.
- Vertical separation distances are measured from the bottom of the Advanced Enviro-Septic™ pipe.

Section G

Design Guide and Sizing Tables

Distribution Configurations

Effluent may be distributed in Advanced Enviro-Septic™ Elevated or In-Ground Bed systems installed using:

- Basic Serial & Butterfly distribution
 - D-Box Configuration distribution
 - Combination Serial distribution
 - Multiple Bed distribution
 - Non-Conventional Configurations
-

Design Notes

- Maximum row length is 100 ft. and minimum row length is 30 ft. (for exceptions, see Non-Conventional Configurations, pp. 19-21.)
- VT linear loading rates must always be honored for all perc. rates.
- Ten foot increments work best and minimize waste.
- Preferred design in soils with perc rates 61-120 is as long and narrow as the site will permit.
- End-to-end bed configurations are preferred to side-to-side bed configurations.
- Multibed separation distance is measured from System Sand edge to System Sand edge.
- System slope maximum is 20% without a state waiver.
- Advanced Enviro-Septic™ rows must be laid level end-to-end to within 1 in. and preferably should be parallel to the contour of the site.
- System should not be located where surface waters concentrate.
- Horizontal Separation Distances are measured from the outermost edge of the System Sand.
- Vertical Separation Distances are measured from the bottom of the Advanced Enviro-Septic™ pipe.
- System Sand bed lengths and widths are always a minimum of 2 ft. longer than row lengths and pipe layout width due to the required 1 ft. minimum of System Sand on all four sides of the Advanced Enviro-Septic™ pipes.
- Center-to-center spacing between pipes is a minimum of 1.5 ft. and varies depending upon the system slope and the perc rate of the soil. Refer to Table B on p. 31.
- Center-to-center spacing variation tolerance is 2 in. (+/- 1 in.)
- Systems sloping more than 10% require a System Sand extension area 6 in. deep that extends 3 ft. from the edge of the System Sand bed on the down slope side (4 ft. from edge of lowest AES pipe).
- All sections within a bed must contain at least the minimum length of pipe required for each section.
- Each bed must contain a minimum of two rows.
- Basic serial system may be used for daily flows of 900 gpd or less.
- Flow equalizers are required whenever flow is being divided.
- Flow equalizers are limited to 20 gpm of flow per equalizer.
- System Sand bed area can never be less than 50% of area requirements of pipe and stone for the same daily flow (Tables D & G have already taken the 50% reduction and do not require further calculation).

Design Notes, Continued

- Venting is **required** for all systems.
 - All systems require proper soil cover and grading (Refer to Section M, Installation Requirements, Component Handling and Site Preparation, pp. 50-53).
-

Loading Limit Specifications

- Each Advanced Enviro-Septic™ System bed with Basic Serial distribution may receive no more than 900 GPD of effluent.
- Each section with Combination Serial distribution may receive no more than 500 GPD.

Example: daily design flow of 950 GPD requires $(950 \div 500) = 1.9$, rounding up to two Serial Sections minimum (distribution box will use two outlets)

Design Sizing Procedures

Task 1: Determine the minimum linear feet of Advanced Enviro-Septic™ pipe required.

Use the percolation rate and the number of bedrooms or the commercial GPD in Table A below to determine the minimum linear feet of pipe required.

Sizing Table A: Minimum Linear Footage (1 – 60 MPI)

Perc. rate Min/In.	Number of Bedrooms						Add'l Room	Commercial Per 100 GPD
	2	3	4	5	6			
1 - 4	85	123	165	207	249	42	47	
5 - 6	90	135	180	225	270	45	50	
7 - 9	100	150	200	250	300	50	55	
10 - 13	110	165	220	275	330	55	60	
14 - 19	120	180	240	300	360	60	66	
20 - 30	130	195	260	325	390	65	71	
31 - 40	140	210	280	350	420	70	77	
41 - 50	150	225	300	375	450	75	83	
51 to 60	160	240	320	400	480	80	89	

Example: A four-bedroom home with a 7 min/inch perc. rate requires 200 feet of pipe.

Task 2: Determine the percentage of slope of the proposed system.

Note: The maximum slope for a system is 20%. In some cases, sites with slopes exceeding 20% may be re-graded and reshaped to provide adequate leachfield sites per Vermont rules. In some instances slopes of up to 25% may be acceptable. Refer to “Sloping Sites,” p. 25, for additional information.

Do you know the percentage of slope of the proposed system?

If yes, go to Task 3.

If no, follow this procedure to determine the percentage of system slope.

Step	Action
1	Identify the highest elevation of the proposed location.
2	Identify the lowest elevation of the proposed location.
3	Subtract the lowest elevation from the highest elevation = elevation change.
4	Measure the horizontal distance between the two elevations = horizontal length.
5	Divide the elevation change by the horizontal length = percentage of site slope.
6	Choose a percentage of slope to be used for the system. <u>Note:</u> The system slope does not need to be the same as the site slope.
7	Go to Task 3.

Task 3: Determine the minimum center-to-center pipe spacing.

Use the perc. rate and the percentage of system slope in Table B below to determine the required minimum center-to-center pipe spacing.

Table B: Pipe Spacing Perc Rates 1 to 60

Percentage of System Slope	Percolation Rate					
	1 - 10	11 - 20	21 - 30	31 - 40	41 - 50	51 - 60
0 - 10%	1.5'	1.5'	1.75'	2.0'	2.5'	3.0'
11 - 15%	1.5'	1.75'	2.0'	2.25'	2.75'	3.25'
16 - 20%	1.75'	2.0'	2.25'	2.5'	3.0'	3.5'

Example: A system slope of 10% or less with a 7 min/inch perc. rate requires pipe spacing of 1.5'.

Task 4: Determine system length and width.

IF...	THEN use Table C below to...
system length is most critical	<ul style="list-style-type: none"> Find the system length in the left column. Minimum row length is determined by Vermont linear loading requirements. Follow that row across to a number equal to or greater than the required total linear feet of Enviro-Septic® Follow that column down through the number of lines row and across left to the required center-to-center spacing.
system width is most critical	<ul style="list-style-type: none"> Find the pipe spacing in the bottom left hand column and follow that row across to the desired width Follow that column up through the number of lines row and up to the required total linear feet of Enviro-Septic® Follow that row left to determine the system length.

Table C: System Pipe Length and Width

System Length/Ft	Total Linear Feet of Advanced Enviro-Septic®														
	40	60	80	100	120	140	160	180	200	220	240	260	280	300	
20	40	60	80	100	120	140	160	180	200	220	240	260	280	300	
25	50	75	100	125	150	175	200	225	250	275	300	325	350	375	
30	60	90	120	150	180	210	240	270	300	330	360	390	420	450	
35	70	105	140	175	210	245	280	315	350	385	420	455	490	525	
40	80	120	160	200	240	280	320	360	400	440	480	520	560	600	
45	90	135	180	225	270	315	360	405	450	495	540	585	630	675	
50	100	150	200	250	300	350	400	450	500	550	600	650	700	750	
55	110	165	220	275	330	385	440	495	550	605	660	715	770	825	
60	120	180	240	300	360	420	480	540	600	660	720	780	840	900	
65	130	190	260	325	390	455	520	585	650	715	780	845	910	975	
70	140	210	280	350	420	490	560	630	700	770	840	910	980	1050	
75	150	225	300	375	450	525	600	675	750	825	900	975	1050	1125	
80	160	240	320	400	480	560	640	720	800	880	960	1040	1120	1200	
85	170	255	340	425	510	595	680	765	850	935	1020	1105	1190	1275	
90	180	270	360	450	540	630	720	810	900	990	1080	1170	1260	1350	
95	190	285	380	475	570	665	760	855	950	1045	1140	1235	1330	1425	
100	200	300	400	500	600	700	800	900	1000	1100	1200	1300	1400	1500	
# of Rows	2	3	4	5	6	7	8	9	10	11	12	13	14	15	
Spacing															
1.50	2.50	4.00	5.50	7.00	8.50	10.00	11.50	13.00	14.50	16.00	17.50	19.00	20.50	22.00	
1.75	2.75	4.50	6.25	8.00	9.75	11.50	13.25	15.00	16.75	18.50	20.25	22.00	23.75	25.50	
2.00	3.00	5.00	7.00	9.00	11.00	13.00	15.00	17.00	19.00	21.00	23.00	25.00	27.00	29.00	
2.25	3.25	5.50	7.75	10.00	12.25	14.50	16.75	19.00	21.25	23.50	25.75	28.00	30.25	32.50	
2.50	3.50	6.00	8.50	11.00	13.50	16.00	18.50	21.00	23.50	26.00	28.50	31.00	33.50	36.00	
2.75	3.75	6.50	9.25	12.00	14.75	17.50	20.25	23.00	25.75	28.50	31.25	34.00	36.76	39.50	
3.00	4.00	7.00	10.00	13.00	16.00	19.00	22.00	25.00	28.00	31.00	34.00	37.00	40.00	43.00	
3.25	4.25	7.50	10.75	14.00	17.25	20.50	23.75	27.00	30.25	33.50	36.75	40.00	43.25	46.50	
3.50	4.50	8.00	11.50	15.00	18.50	22.00	25.50	29.00	32.50	36.00	39.50	43.00	46.50	50.00	
3.75	4.75	8.50	12.25	16.00	19.75	23.50	27.25	31.00	34.75	38.50	42.25	46.00	49.75	53.50	
4.00	5.00	9.00	13.00	17.00	21.00	25.00	29.00	33.00	37.00	41.00	45.00	49.00	53.00	57.00	
4.25	5.25	9.50	13.75	18.00	22.25	26.50	30.75	35.00	39.25	43.50	47.75	52.00	56.25	60.50	
4.50	5.50	10.00	14.50	19.00	23.50	28.00	32.50	37.00	41.50	46.00	50.50	55.00	59.50	64.00	
4.75	5.75	10.50	15.25	20.00	24.75	29.50	34.25	39.00	43.75	48.50	53.25	58.00	62.75	67.50	
5.00	6.00	11.00	16.00	21.00	26.00	31.00	36.00	41.00	46.00	51.00	56.00	61.00	66.00	71.00	

Pipe Layout Width in feet (outermost width of rows)

Task #5: Determine System Sand Bed Area required

**Vermont Rules
System Sand
area**

- At no time may an Advanced Enviro-Septic™ system be designed to have a System Sand footprint less than 50% of a stone and pipe system.
- Use Vermont rules to determine daily flow; Table D below assumes one person occupancy for the fourth and additional bedrooms.
- Sand fill cannot be included in the System Sand footprint when determining the minimum sand bed area required.
- Table D reflects the 50% reduction in area allowed by Vermont and may be used without further calculation or reduction.

Table D – Vermont Minimum System Sand Bed Area

Perc. Rate Min./In.	Bedrooms						Commercial per 100 gpd
	2	3	4	5	6	Add'l	
1-4	117	175	205	234	263	30	42
5 - 6	143	215	251	286	322	36	52
7 - 8	165	248	289	330	372	42	59
9 - 10	185	277	323	369	416	47	66
11 - 12	203	304	354	405	455	51	73
13 - 14	219	328	382	437	492	55	78
15 - 16	234	350	409	467	525	59	84
17 - 18	248	372	434	495	557	62	89
19 - 20	261	392	457	522	587	66	94
21 - 22	274	411	479	548	616	69	98
23 - 24	286	429	501	572	643	72	103
25 - 26	298	447	521	595	670	75	107
27 - 28	309	464	541	618	695	78	111
29 - 30	320	480	560	640	719	80	115
31 - 32	330	495	578	660	743	83	118
33 - 34	341	511	596	681	766	86	122
35 - 36	350	525	613	700	788	88	125
37 - 38	360	540	630	720	810	90	129
39 - 40	369	554	646	738	831	93	132
41 - 42	379	568	662	757	851	95	136
43 - 44	387	581	678	774	871	97	139
45 - 46	396	594	693	792	891	99	142
47 - 48	405	607	708	809	910	102	145
49 - 50	413	619	722	825	929	104	148
51 - 52	421	631	737	842	947	106	151
53 -54	429	643	751	858	965	108	154
55 - 56	437	655	764	874	983	110	156
57 - 58	445	667	778	889	1,000	112	159
59 - 60	452	678	791	904	1,017	113	162
Square Feet of System Sand Required Minimum							

Example: A five bedroom residence, 560 gpd, at 18 mpi requires a minimum 495 sq.ft. of System Sand.

**Design
Procedure**

Task #1: Determine the Daily Design Flow using Vermont requirements. Select the required amount of Advanced Enviro-Septic pipe from Table A on p. 30 based on the Daily Design Flow and site percolation rate.

Task #2: Determine the System Slope for the proposed bed. Maximum System Slope is 20% by Vermont rule. See Vermont rules for possible exceptions.

Task #3: Based on the System Slope and percolation rate for the site, select the appropriate Center-to-Center row spacing from Table B on p. 31.

Task #4: Determine the System Length and Width using Table C on p. 32.

Task #5: Using the Daily Design Flow and percolation rate, determine the System Sand Bed Area using Table D on p. 33. Table D shows the minimum System Sand bed area required after taking a 50% reduction in the bed sizing required for pipe and stone systems. No further reduction is required or allowed.

Note: System Sand Bed Length must always meet or exceed Vermont linear loading requirements.

**Design
Example #1
Single Family
Residence**

Task #1, Daily Design Flow = three bedrooms; AES pipe required from Table A for 14 mpi perc rate = 180 ft. min.

Task #2, System Slope is 10%

Task #3, Using 10% System Slope and 14 mpi perc rate, Table B requires a row spacing = 1.5 ft. min.

Task #4, Using a row length of 60 ft. and 1.5 ft. row spacing, Table C shows three rows will be required to provide the minimum 180 ft. of AES pipe. Table C also shows the Pipe Layout Width will be 4 ft. The System Sand Bed Width is 4 ft. + 2 ft. of perimeter System Sand around the pipes for a total of 6 ft.

Task #5, Using three bedrooms and 14 mpi, Table D requires 328 sq. ft. of System Sand Bed Area. From Task #4 above, the System Sand Bed Length using a 60 ft. row length, is 62 ft. The minimum System Sand bed width is calculated by dividing 328 by 62, which = 5.29 ft. min. The System Sand Bed Width from Task #4 is 6 ft. This exceeds the 5.29 ft. minimum just calculated, so no increase in row spacing is required.

Note: Verify length meets or exceeds Vermont linear loading requirement (not considered in this example).

**Design
Example #2
Single Family
Residence**

Task #1, Daily Design Flow = seven bedrooms; AES pipe required from Table A using 60 mpi perc rate = 560 ft. Take the pipe required for 6 bedrooms (480 ft.) and add and additional (80 ft.) from the “Add'l Room” column.

Task #2, System Slope to be used is 20%.

Task #3, Using 20% System Slope and 60 mpi, Table B requires a row spacing of 3.5 ft. minimum.

Task #4, Using a row length of 100 ft. and 3.5 ft. row spacing, Table C shows six rows will be required to provide the minimum 560 ft. of AES pipe. Table C also shows the Pipe Layout Width will be 18.5 ft. The System Sand Bed Width is 18.5 ft. + 2 ft. of perimeter System Sand + 3 ft. of System Sand Extension because the System Slope is over 10%, which totals 23.5 ft.

Task #5, Using seven bedrooms and 60 mpi, Table D requires 1,130 sq. ft. minimum of System Sand Bed Area. From Task #4 above, the System Sand Bed Length is 102 ft. The minimum System Sand bed width is determined by dividing 1,130 by 102, which = 11.08 ft. minimum. The System Sand Bed Width from Task #4 is 23.5 ft., which exceeds the 11.08 ft. minimum just calculated, so no increase in row spacing is required.

Note: verify length meets or exceeds Vermont linear loading requirement (not consider in this example).

**Design
Example #3
Commercial**

Task #1, Daily Design Flow = 500 gallons per day; AES pipe required from Table A using 5 mpi perc rate = 250 ft. Take the pipe required for 100 gpd (50 ft.) and multiply by 5 (500/100.) from the “Commercial per 100 gpd” column.

Task #2, System Slope to be used is 0%.

Task #3, Using 0% System Slope and 5 mpi, Table B requires a row spacing of 1.5 ft. minimum.

Task #4, Using a row length of 50 ft. and 1.5 ft. row spacing, Table C shows five rows will be required to provide the minimum 250 ft. of AES pipe. Table C also shows the Pipe Layout Width will be 7 ft. The System Sand Bed Width is 7 ft. + 2 ft. of perimeter System Sand, which totals 9 ft.

Task #5, Using 500 gpd and 5 mpi, Table D requires 260 sq. ft. minimum (500/100 x 52) of System Sand Bed Area. From Task #4 above, the System Sand Bed Length is 52 ft. The minimum System Sand Bed Width is determined by dividing 260 by 52, which = 5 ft. minimum. The System Sand Bed Width from Task #4 is 9 ft., which exceeds the 5 ft. minimum just calculated, so no increase in row spacing is required.

Note: verify length meets or exceeds Vermont linear loading requirement (not consider in this example).

Bed Sizing Procedure & Worksheet

<p>1. <u>Effluent Loading</u> Determine the system's daily effluent loading in total number of bedrooms or gpd for commercial systems.</p> <p>Two bedrooms for residential minimum & 300 gpd minimum for commercial systems.</p>	<p>1. Loading in Bedrooms or gpd</p> <p>(2) bedroom min. or 300 gpd for comm..</p>	<div style="border: 1px solid black; height: 100%; width: 100%;"></div>
<p>2. <u>AES Pipe Required</u> Using Table A determine the linear footage of AES pipe required for the daily design flow from Task #1 above and the site's percolation rate (mpi).</p>	<p>MPI =</p> <p>2. AES pipe required (ft.) From Table A</p>	<div style="border: 1px solid black; height: 100%; width: 100%;"></div>
<p>3. <u>Determine System Slope</u> Determine the System Slope to be used expressed as a %.</p> <p>System Slope cannot exceed 20% without a waiver</p>	<p>3. System Slope 0% to 20%</p>	<div style="border: 1px solid black; height: 100%; width: 100%;"></div>
<p>4. <u>Determine Minimum Row Spacing</u> Using Table B, find the System Slope from Task #3 to determine the minimum center-to-center row spacing.</p> <p>Never less than 1.5 ft. center-to-center</p>	<p>4. Min. row spacing from Table B Not less than 1.5 ft.</p>	<div style="border: 1px solid black; height: 100%; width: 100%; text-align: center;"> <p>-----</p> </div>
<p>5. <u>Determine System Row Length</u> Using Table C, site constraints and VT linear loading requirements, select a pipe row length. Find Pipe Layout Width (PLW) for row spacing from Task #4.</p> <p>Calculate System Sand Bed Width (SSBW) by adding 2 ft. to PLW if System Slope is 10% & less or by adding 5 ft. to PLW if System Slope is over 10%</p> <p>Pipe Layout Width (ft.) PLW System Sand Bed Width (ft.) SSBW System Sand Bed Length (ft.) SSBL</p>	<p>Site Slope =</p> <p>LLR =</p> <p>SSBL min. =</p> <p>5. Select row length, find PLW, note # of rows, SSBW & SSBL</p>	<p># Rows =</p> <p>PLW =</p> <p>SSBW =</p> <p>SSBL =</p> <div style="border: 1px solid black; height: 100%; width: 100%; text-align: center;"> <p>-----</p> </div>
<p>6. <u>System Sand Bed Area</u> Using Table D, find the minimum System Sand Bed Area (SSBA) for the daily design flow from Task #1.</p> <p>Divide the SSBA by the System Sand Bed Length (SSBL) to determine minimum sand bed width.</p> <p>Verify System Sand Bed Width from Task #5 meets or exceeds this value or increase SSBW.</p>	<p>SSBA /SSBL = SSBW</p> <p>6. System Sand Bed Area min. (sf)</p>	<p>SF Required =</p> <div style="border: 1px solid black; height: 100%; width: 100%; text-align: center;"> <p>-----</p> </div> <p>SF Provided =</p>

Section H

Percolation Rates from 61 – 120 Minutes per Inch

Introduction	Systems in high-density soils (soils with slow percolation rates) are limited in configuration in order to disperse and treat effluent adequately and to minimize groundwater mounding.								
Purpose	The purpose of this guide is to help designers choose system layouts for percolation rates in the 61-120 minutes/inch range.								
Reminder	All systems with percolation rates of 61-120 minutes per inch must be designed as mounds/elevated and each bed is limited to 500 gpd.								
Exceptions require variance	Exceptions to any requirements used in this quick reference guide require a variance.								
Distance measurements	The distances used in this guide, including minimum distances required by the Vermont rules. SHWT and restrictive features are measured from the bottom of the Advanced Enviro-Septic [®] pipe.								
Number of Rows Required	<p>Beds with percolation rates of 61 – 120 minutes per inch may use in-line rows of Advanced Enviro-Septic[™] pipe in order to meet Vermont linear loading requirements. Two rows minimum required. More rows allowed, but never less than 30 ft. or longer than 100 ft. In-line rows connected together using straight raised connectors (see p. 15 for illustration).</p> <p>Example: Linear loading requires bed length of 162 ft. for a two bedroom residence needing 160 ft. of AES pipe. This bed would require two rows (in a straight line) with each row 80 ft. long.</p>								
Slope percentages allowed	Use Table E below to determine system slope percentages allowed.								
	<p>Table E – Maximum System Slopes for Perc. Rates 61-120 MPI</p> <table border="1" style="margin-left: auto; margin-right: auto;"> <thead> <tr> <th style="text-align: center;">Perc. Rate</th> <th style="text-align: center;">% System Slope</th> </tr> </thead> <tbody> <tr> <td style="text-align: center;">61-70</td> <td style="text-align: center;">15%</td> </tr> <tr> <td style="text-align: center;">71-90</td> <td style="text-align: center;">10%</td> </tr> <tr> <td style="text-align: center;">91-120</td> <td style="text-align: center;">0%</td> </tr> </tbody> </table>	Perc. Rate	% System Slope	61-70	15%	71-90	10%	91-120	0%
Perc. Rate	% System Slope								
61-70	15%								
71-90	10%								
91-120	0%								
Additional site preparation requirement	<p>Remove grass, cut brush to ground level, and mold board plow to an approximate depth of 9 inches.</p> <p>Also see mound construction procedure in Vermont rules.</p>								
Row Spacing	Systems placed on soils with perc. rates over 61 mpi will have a minimum 1.5 ft. center-to-center row spacing. Systems that are level require the rows to be centered in the System Sand bed width. Systems that slope will group the rows starting at the high contour.								
System Sand Bed Length	Minimum System Sand Bed Length is determined by Vermont linear loading requirements.								

**Table F: Minimum Linear Footage
Perc Rates 61 - 120**

Perc. rate Min/Inch	Number of Bedrooms						Commercial Per 100 GPD
	2	3	4	5	6	Add'l Room	
61 - 120	160	240	320	400	480	80	90
Advanced Enviro-Septic™ pipe required minimum (ft.)							

Table G: Minimum System Sand Bed Area

Perc. Rate MPI	Bedrooms						Each Add'l	Commercial Per 100 gpd
	2	3	4	5	6			
61 - 62	460	689	804	919	1,034	115	165	
63 - 64	467	700	817	934	1,050	117	167	
65 - 66	474	711	830	948	1,067	119	170	
67 - 68	482	722	842	963	1,083	121	172	
69 - 70	489	733	855	977	1,099	123	175	
71 - 72	495	743	867	990	1,114	124	177	
73 - 74	502	753	879	1,004	1,130	126	180	
75 - 76	509	763	890	1,018	1,145	128	182	
77 - 78	516	773	902	1,031	1,160	129	184	
79 - 80	522	783	914	1,044	1,174	131	187	
81 - 82	529	793	925	1,057	1,189	133	189	
83 - 84	535	802	936	1,070	1,203	134	191	
85 - 86	541	812	947	1,082	1,218	136	194	
87 - 88	548	821	958	1,095	1,232	137	196	
89 - 90	554	831	969	1,107	1,246	139	198	
91 - 92	560	840	980	1,120	1,259	140	200	
93 - 94	566	849	990	1,132	1,273	142	202	
95 - 96	572	858	1,001	1,144	1,286	143	205	
97 - 98	578	867	1,011	1,155	1,300	145	207	
99 - 100	584	875	1,021	1,167	1,313	146	209	
101 - 102	590	884	1,031	1,179	1,326	148	211	
103 - 104	595	893	1,042	1,190	1,339	149	213	
105 - 106	601	901	1,052	1,202	1,352	151	215	
107 - 108	607	910	1,061	1,213	1,364	152	217	
109 - 110	612	918	1,071	1,224	1,377	153	219	
111 - 112	618	927	1,081	1,235	1,390	155	221	
113 - 114	623	935	1,090	1,246	1,402	156	223	
115 - 116	629	943	1,100	1,257	1,414	158	225	
117 - 118	634	951	1,109	1,268	1,426	159	227	
119 - 120	640	959	1,119	1,279	1,438	160	229	
Square Feet of System Sand Required Minimum								

Note: Use Vermont Linear Loading Rates to determine bed length.

Rows centered on System Sand for level beds

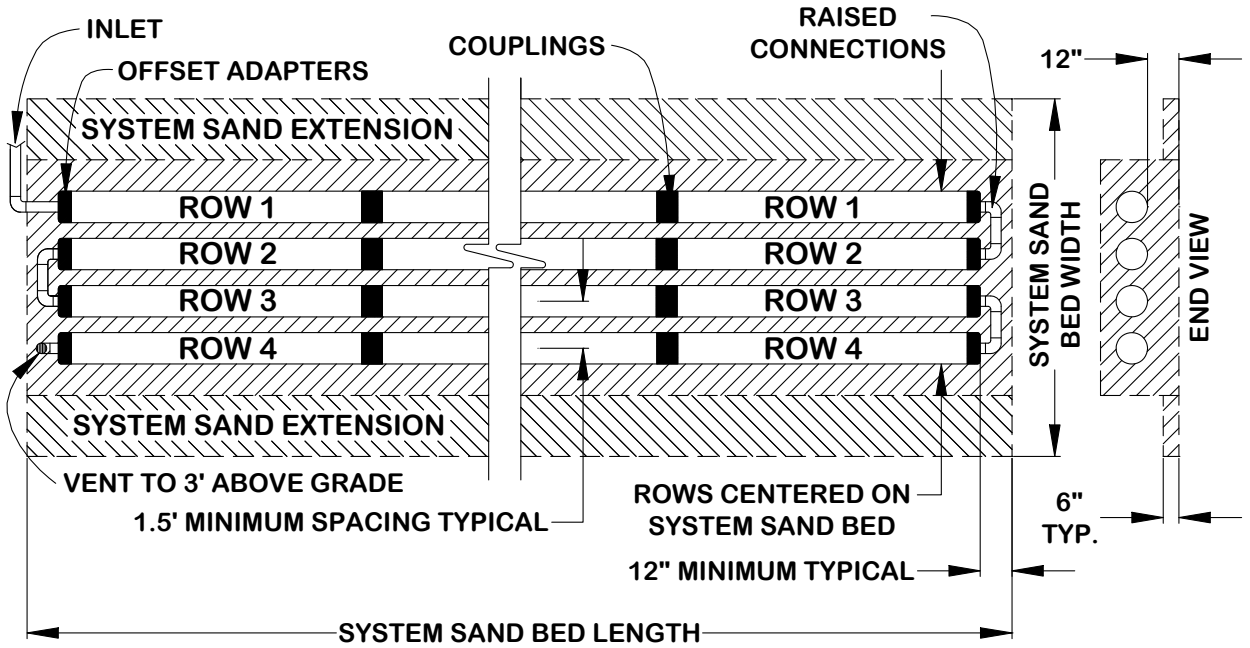

Note: must be designed as a mound system.

Rows grouped at high contour for sloping beds

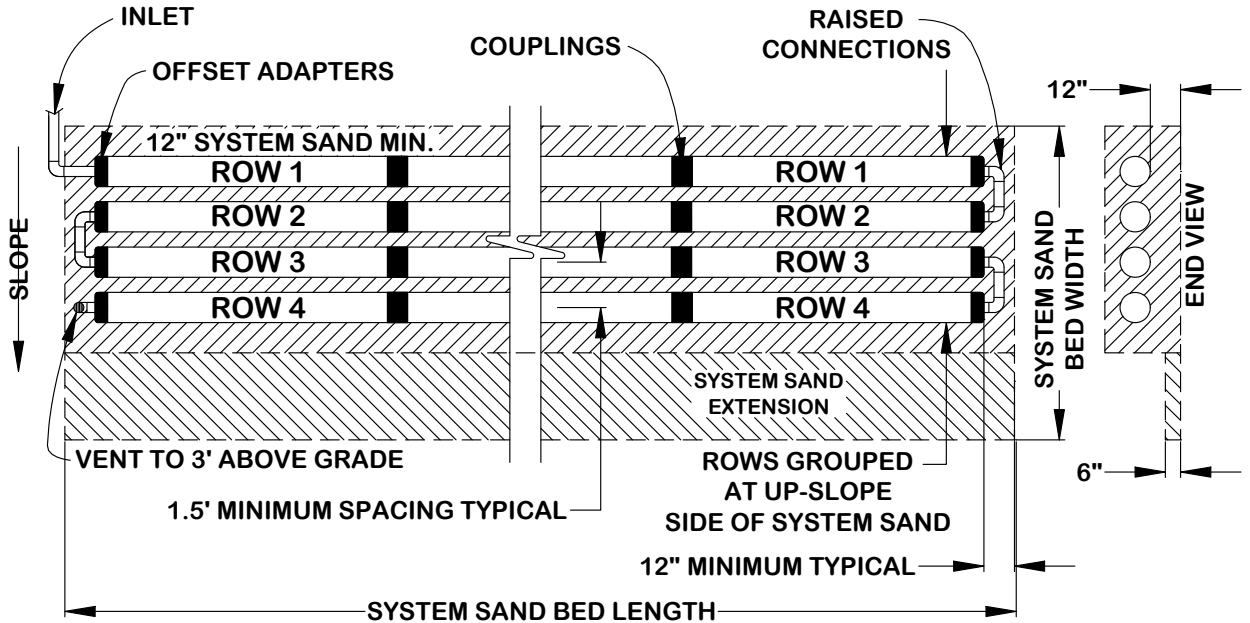

Note: must be designed as a mound system.

Notes for In-Line Beds

- Two rows minimum
- Row length 30 ft. min. – 100 ft. max.
- All rows of equal length
- Rows connected with Raised Straight Connectors
- Three ft. minimum bed width
- Rows centered in System Sand for level beds
- Rows grouped at high contour for sloping beds
- System Sand bed length per Vermont linear loading requirements

In-Line Rows for level bed:

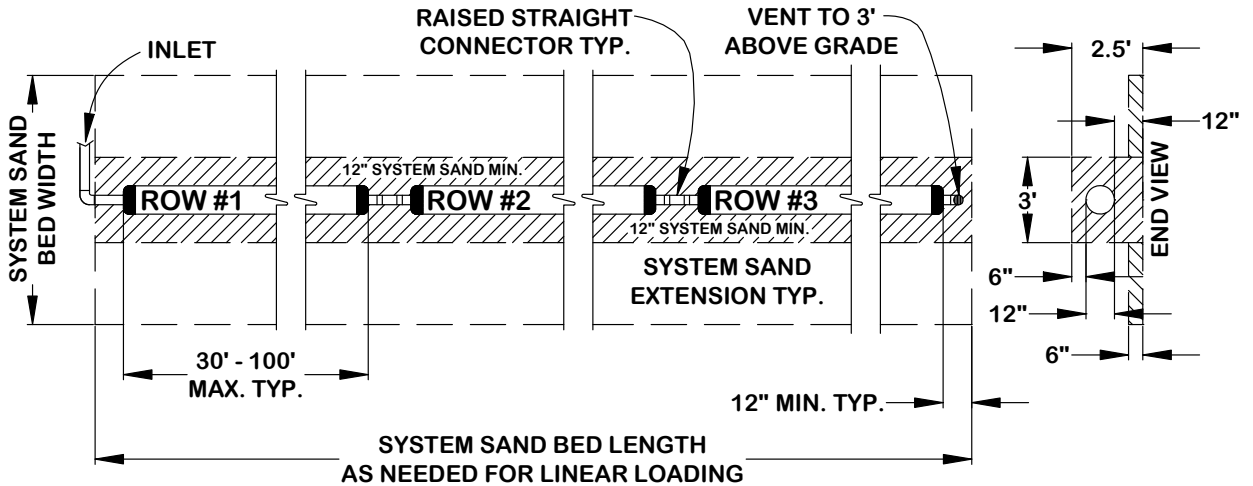

In-Line rows for sloping bed:

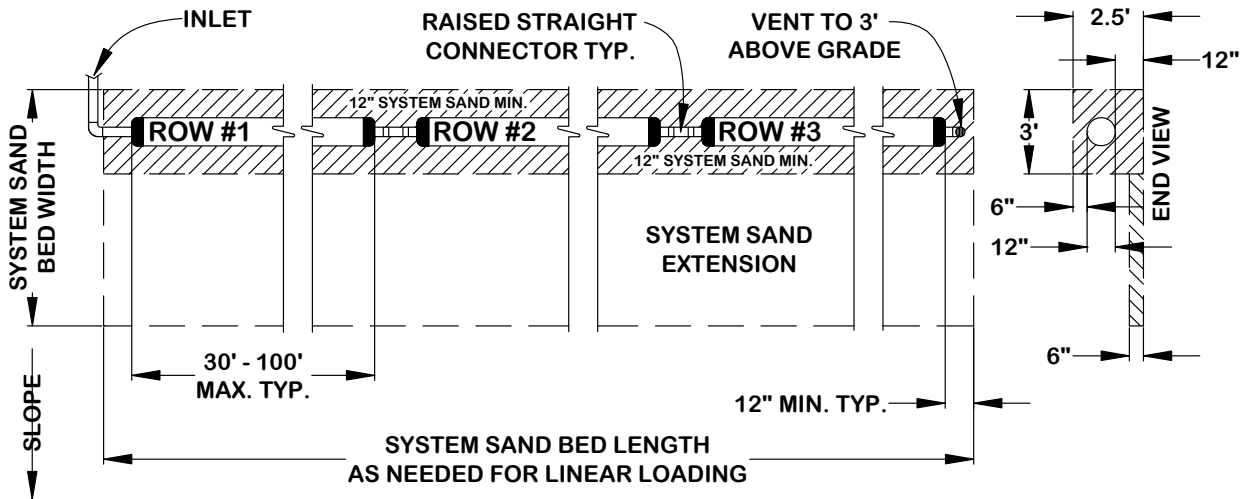

Section I

System Sand and Fill Material Specifications

“System Sand” Requirements

It is **critical** to the proper functioning of the Advanced Enviro-Septic™ System that the proper amount and type of System Sand be installed. System Sand must be clean, granular sand free of organic matter and must adhere to Vermont §1-913(c),(2) fill material, except:

- Fines Quality Restrictions: A maximum of 2% of total sand may pass through a #200 sieve (verified by washing sample per requirements of ASTM C-117 as noted in the ASTM C-33 specification).
- ASTM C-33 (“concrete sand”) may be acceptable for use as System Sand providing that no more than 2% can pass a #200 sieve (verified by washing sample per requirements of ASTM C-117 as noted in the ASTM C-33 specification).

System Sand is placed a minimum of 6 in. below the Advanced Enviro-Septic™ rows for below grade systems, a minimum of 12 in. below the Advanced Enviro-Septic™ rows for mound/elevated systems, a minimum of 6 in. above the Advanced Enviro-Septic™ rows, and a minimum of 12 in. horizontally around the perimeter of the Advanced Enviro-Septic™ rows.

Note: System Sand may be used in place of sand fill; however, this may increase material costs.

Sand Fill

Sand fill is used to raise the elevation of the system in order to meet the required separation distance from the SHWT or other restrictive feature. Sand fill is defined by Vermont §1-913(c). No organic material is allowed. If §1-913(c)(2) material is used, no more than 5% shall pass a #200 sieve.

Note: Sand fill is not suitable for use as System Sand, however System Sand may be used in place of sand fill.

Topsoil (a.k.a. “Loam”)

Suitable earth cover, similar to the naturally occurring soil at the site and capable of sustaining plant growth, is required as the uppermost layer over the entire system (and extensions). The topsoil layer should be a minimum of 4 in. deep and should be immediately seeded or mulched in order to prevent erosion.

Pumped System Requirements, continued

Dose Volume

- Pump volume per dose must be no greater than 1 gallon times the total linear feet of Advanced Enviro-Septic™ pipe.
 - Pump dosing should be designed for a minimum of 6 cycles per day.
 - If possible, it is recommended that the dosing cycle should provide one hour of drying time between doses.
-

Basic Serial Distribution Limit

Pumped systems with Basic Serial distribution are limited to a maximum dose rate of 40 gallons per minute. Never pump directly into Advanced Enviro-Septic™ pipe.

Combination and Multiple-Bed Distribution Limit

All Advanced Enviro-Septic™ Systems with Combination Serial distribution or Multiple Bed distribution must use flow equalizers in each distribution box outlet. Each Bed or section of Combination Serial distribution is limited to a maximum of 20 gallons per minute, due to the flow constraints of equalizers.

Example: pumping to a combination system with 3 sections (using 3 d-box outlets). The maximum delivery rate is $(3 \times 20) = 60$ GPM. Always provide a means of velocity reduction!

Section K Venting Requirements

General Rules

- An adequate supply of air is **essential** to the proper functioning of the Advanced Enviro-Septic™ System.
- Venting as described below is **required** for all systems.
- Vent openings must be located to ensure the unobstructed flow of air through the entire Advanced Enviro-Septic™ System.
- The low vent inlet must be a minimum of 3 ft. from final grade.
- One 4 in. vent is required for every 1,000 feet of Advanced Enviro-Septic™ pipe.
- A single 6 in. vent may be installed in place of up to three 4 in. vents.
- If a vent manifold is used, it must be the same diameter as the vent(s).
- When venting multiple beds, it is preferred that each bed be vented separately rather than manifolding bed vents together.
- Remote Venting (see p. 47, this Section) may be utilized to minimize the visibility of vent stacks.

Differential Venting

- Differential venting is the use of high and low vents in a system.
- In a gravity system, the roof stack acts as the high vent.
- High and low vent openings **must** be separated by a minimum of 10 vertical feet.
- If possible, the high and low vents should be of the same capacity.
- Sch. 40 PVC or equivalent should be used for all high vents.

Vent Locations

Vent locations depend upon the type of system.

Gravity Systems

- A low vent through an offset adapter is installed at the end of the last row of each section or the end of the last row in a Basic Serial bed, or at the end of each row in a D-Box Distribution Configuration system. A vent manifold may be used to connect the ends of multiple sections or rows.
- **The house (roof) vent functions as the high vent** as long as there are no restrictions or other vents between the low vent and the house (roof) vent.
- **When the house (roof) vent functions as the high vent, there must be a minimum of a 10 ft. vertical differential between the low and high (roof) vent.**

GRAVITY SYSTEM VENTING CONFIGURATION

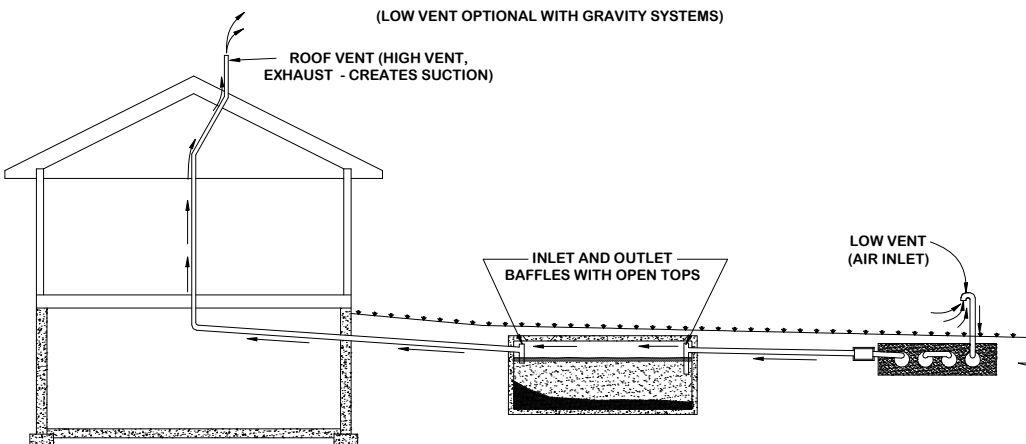

VENTING IS ESTABLISHED THROUGH SUCTION (CHIMNEY EFFECT) CREATED BY THE DRAW OF AIR FROM THE HIGH VENT, WHICH DRAWS AIR FROM THE LOW VENT, THROUGH THE LEACH FIELD, THROUGH THE SEPTIC TANK, AND EXHAUSTED THROUGH THE (HIGH) ROOF VENT.

Venting Requirements, Continued

Pump System Vent Locations

- A low vent is installed through an offset adapter at the end of each section, Basic Serial bed or attached to a vent manifold.
- A high vent is installed through an unused distribution box outlet (see diagram below).
- A 10 ft. minimum vertical differential is required between high and low vent openings.
- When venting multiple beds, it is preferred that each bed be vented separately (have their own high and low vents) rather than manifolding bed vents together.

Differential Venting for Pump Systems

(Typical – Not to Scale)

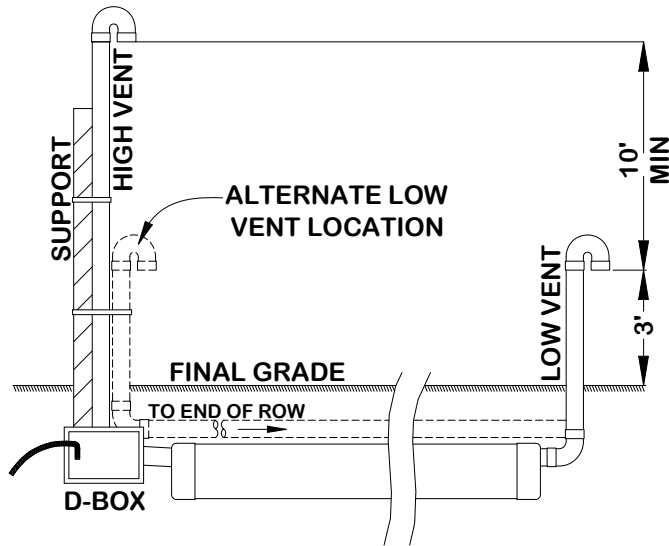

Note: the low vent may be attached to the D-box and the high vent attached to the end of the last row (or manifold) only when the D-box is insulated against freezing.

Vent Manifolds

A vent manifold may be incorporated to connect the ends of a number of sections or rows of Advanced Enviro-Septic™ pipe to a single vent opening. See diagram below.

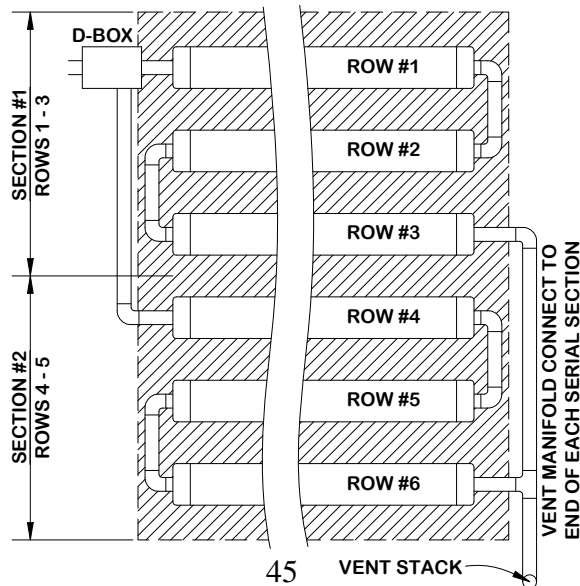

Venting D-Box Configuration

D-box Configurations require the ends of all rows be manifolded together. The vent stack must be attached to the manifolded rows.

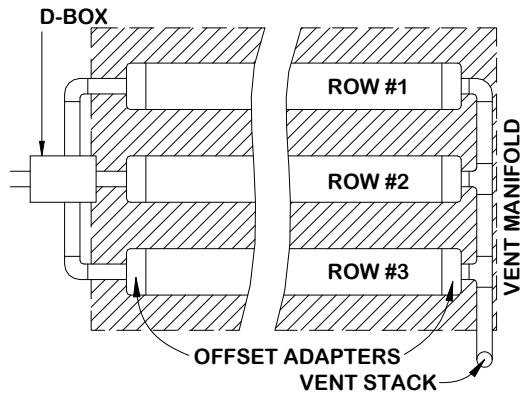

Vent Piping Slope

Vent piping should slope downward toward the system to prevent moisture from collecting in the pipe and blocking the passage of air.

Remote Venting

If site conditions do not allow the vent pipe to slope toward the system, or the owner chooses to utilize remote venting for aesthetic reasons (causing the vent pipe not to slope toward the system), the low point of the vent line must be drilled creating several 1/4 in. holes to allow drainage of condensation. This procedure may **only** be used if the vent pipe connecting to the system has:

- A **high point** that is above the highest point of all Advanced Enviro-Septic™ pipes or the Distribution Box; and,
- A **low point** opened for drainage which is at least 36 in. above the SHWT. (See diagram below.)

REMOTE DIFFERENTIAL VENTING

(NOT TO SCALE)

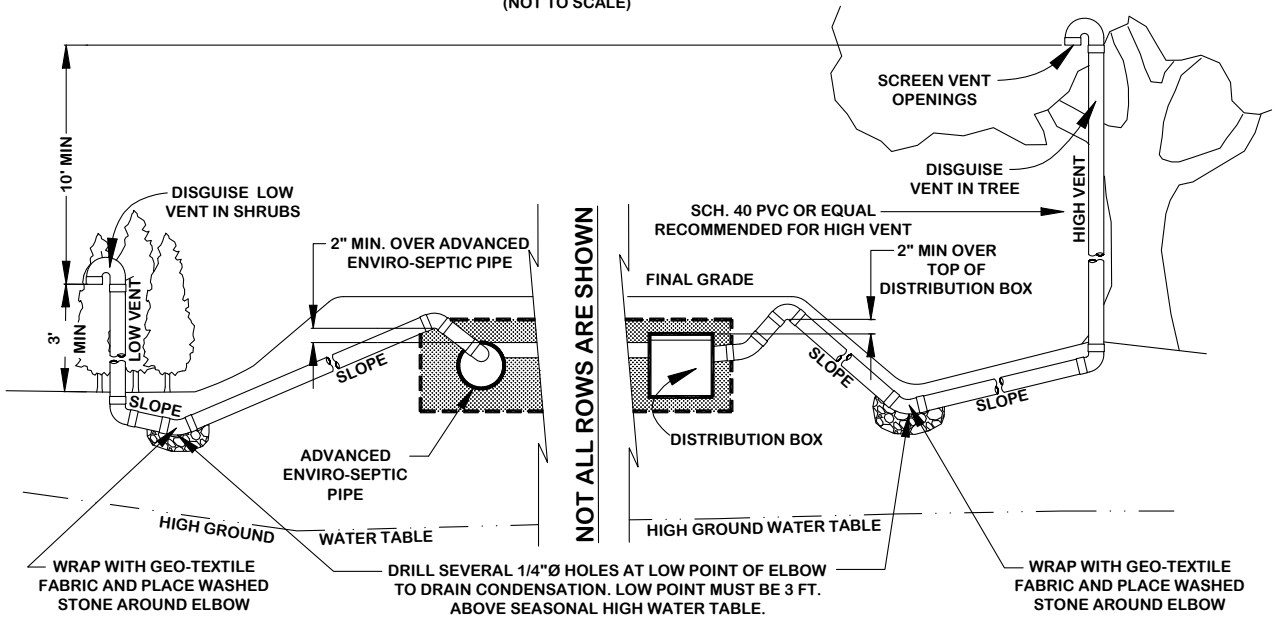

Note: low point of vent(s) with 1/4 in. holes to be 3 ft. minimum above the seasonal high water table and must be outside any water supply isolation zone(s).

BY-PASS VENTING

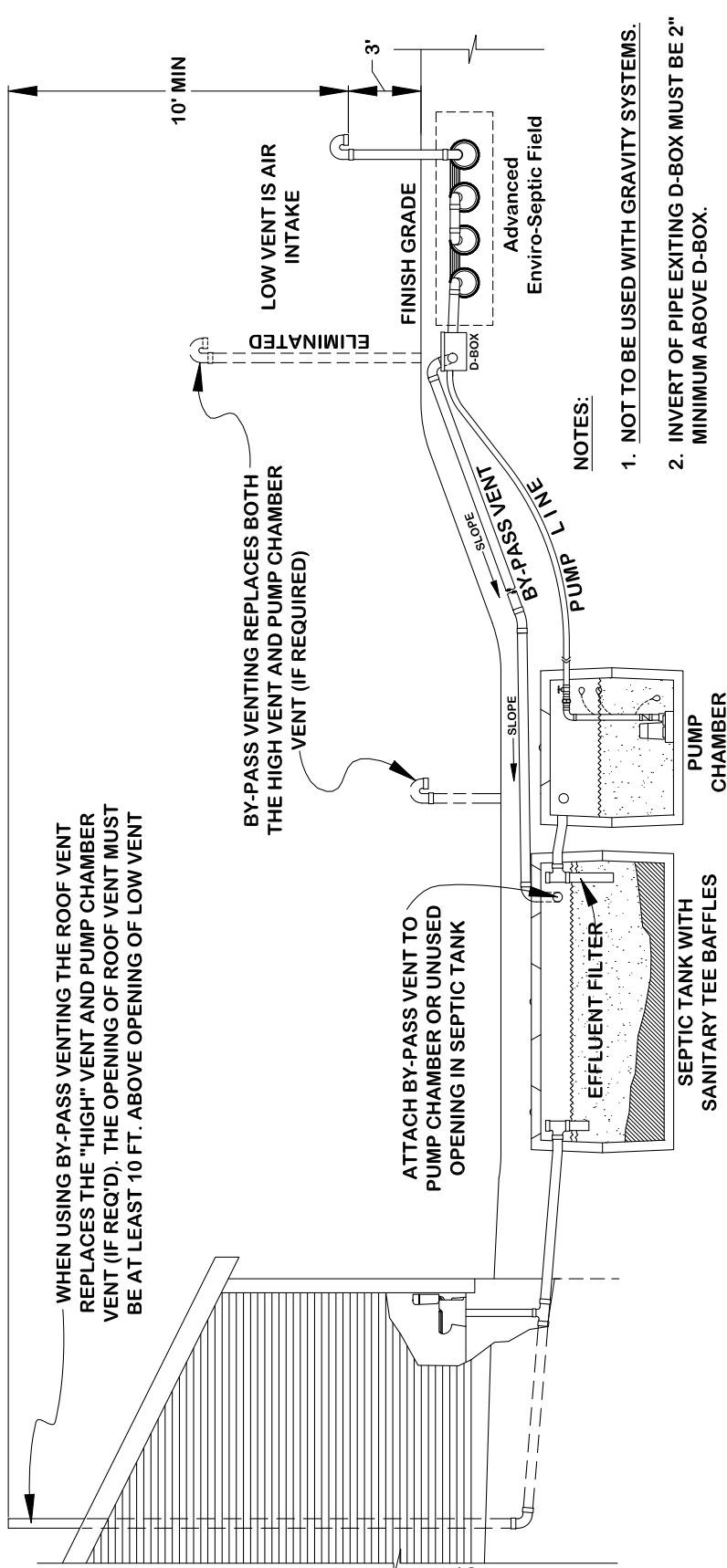

NOTES:

1. NOT TO BE USED WITH GRAVITY SYSTEMS.
2. INVERT OF PIPE EXITING D-BOX MUST BE 2" MINIMUM ABOVE D-BOX.
3. USE 4" SCH. 40 PVC OR EQUAL FOR BY-PASS VENTING.
4. GLUE ALL PVC JOINTS OR EQUAL.

OPTIONAL CONFIGURATION

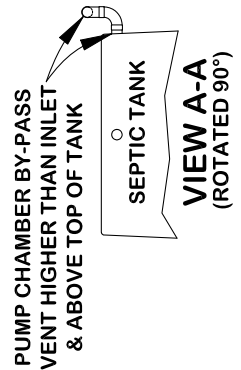
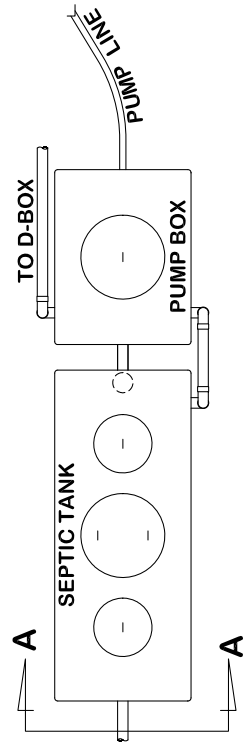

Section L Site Selection

Determining Site Suitability

Refer to Vermont Rules regarding site suitability requirements.

Topography

Locate systems on convex, hill, slope or level locations that do not concentrate surface flows. Avoid swales, low areas, or toe-of-slope areas that may not provide sufficient drainage away from the system.

Surface Water Diversions

Surface water runoff must be diverted away from the system. Diversions must be provided up-slope of the system and designed to avoid ponding. Systems must not be located in areas where surface or groundwater flows are concentrated.

Dispersal area

Systems must be located where adjacent soils in the proposed system location and a 50 ft. perimeter are suitable for dispersing water away from the system.

Systems under traffic bearing surfaced

The State of Vermont does not permit systems to be installed under traffic bearing surfaces.

Containment

Systems should not be located where structures such as curbs, walls or foundations might adversely restrict the soil's ability to transport water away from the system.

Hydraulic loading

Systems should not be located where lawn irrigation, roof drains, or natural flows increase water loading to the soils around the system.

Access

Systems should be located to allow access for septic tank maintenance and to at least one end of all Advanced Enviro-Septic™ rows. Planning for future access will facilitate Rejuvenation in the event the system malfunctions. (Refer to Section N, System Bacteria Rejuvenation and System Expansion, p. 54.)

Rocky or wooded areas

Avoid locating systems in rocky or wooded areas that require additional site work, since this may alter the soil's ability to accept water. No trees or shrubs should be located within 10 ft. of the system to prevent root infiltration.

Reserve Area

Vermont Rules require a reserve area for in ground replacement systems; mound systems do not require a reserve area.

Note: below grade systems must be replaced in accordance with Vermont rules and may require the replacement system to be located in the reserve area.

Section M

Installation Requirements, Component Handling and Site Preparation

Component Handling

- Keep mud, grease, oil, etc. away from all components.
 - Avoid dragging pipe through wet or muddy areas.
 - Store pipe on high and dry areas to prevent surface water and soil from entering the pipes or contaminating the fabric prior to installation.
 - The outer fabric of the Advanced Enviro-Septic™ pipe is ultra-violet stabilized; however, this protection breaks down after a period of time in direct sunlight. To prevent damage to the fabric, cover the pipe with an opaque tarp if stored outdoors.
-

Critical Reminder Prevent Soil Compaction

It is critical to keep excavators, backhoes, and other equipment off the excavated or tilled surface of a bed. Before installing the System Sand, excavation equipment should be operated around the bed perimeter and not on the bed itself

Site Preparation Prior to Excavation

- Locate and stake out the System Sand bed, extension areas and soil material cover extensions on the site according to the approved plan.
 - Install sediment/erosion control barriers prior to beginning excavation to protect the system from surface water flows during construction.
 - Do not travel across or locate excavation equipment within the portion of the site receiving System Sand.
 - Do not stockpile materials or equipment within the portion of the site receiving System Sand.
 - It is especially important to avoid using construction equipment down slope of the system to prevent soil compaction.
-

When to Excavate

- Do not work wet or frozen soils. If a fragment of soil from about 9 in. below the surface can easily be rolled into a wire, the soil moisture content is too high for construction.
 - Do not excavate the system area immediately after, during or before precipitation.
-

Installation Requirements, Component Handling and Site Preparation, continued

Tree Stumps

- Tree stumps shall be cut flush with surface of the ground and roots shall not be pulled.
 - Do not locate equipment within the limits of the System Sand bed.
 - Avoid soil disturbance, relocation, or compaction.
 - Avoid mechanical leveling or tamping of dislodged soil.
 - Fill all voids created by unintentional stump or root removal with System Sand.
-

Raking and Tilling Procedures

All areas receiving System Sand, sand fill and fill extensions **must** be raked or tilled. If a backhoe/excavator is used to till the site, fit it with chisel teeth and till the site. The excavator should remain outside of the proposed System Sand area and extensions. Equipment with tires must never enter the receiving area due to likely wheel compaction of underlying soil structures.

- For **in-ground bed systems**, excavate the system bed as necessary below original grade. Using an excavator or backhoe, tilt the bucket teeth perpendicular to the bed and use the teeth to rake furrows 2 in.- 6 in. deep into the bottom of the entire area receiving System Sand or sand fill (“receiving area”).
 - For **elevated bed systems** remove the “O” horizon (all organics), then use an excavator or backhoe to rake furrows 7 in. – 8 in. deep into the receiving area. Create a transition layer by tilling 6 in. of System Sand or sand fill into the receiving layer prior to bed construction.
-

Organic Material Removal

While tilling, remove all grass, leaves, sticks, brush and other organic matter or debris from the excavated system site. Do not remove topsoil.

Note: It is not necessary for the soil of the system site to be smooth when the site is prepared.

Installation Requirements, Component Handling and Site Preparation, continued

Install System Sand and/or Sand Fill Immediately After Excavation

- To protect the tilled area (System Sand bed area and System Sand extension area) from damage by precipitation, System Sand should be installed immediately after tilling (6 in. for below grade and 12 in. for elevated systems).
 - When installing the System Sand, work off either end or the uphill side of the system to avoid compacting soil (see "**Critical Reminder**" at the beginning of this section).
 - When installing System Sand, keep at least 6 in. of sand between the vehicle tracks and the tilled soil of the site if equipment must work on receiving soil.
 - Track construction equipment should not travel over the installed system area until at least 12 in. of cover material is placed over the Advanced Enviro-Septic™ pipes.
 - Heavy equipment with tires must never enter the receiving area due to likely wheel compaction of underlying soil structures.
-

Distribution Box Installation

To prevent movement, be sure D-boxes are placed level on compacted soil, sand or pea gravel base, or concrete pad.

Level Row Tolerances

Use a laser level or transit to install rows level. Variations beyond 1 in. may affect system performance. Variations beyond a total of 1 in. are **not acceptable**.

Correct Alignment of Bio-Accelerator™

The Bio-Accelerator™ (white geo-textile layer) is to be positioned centered along the bottom of the pipe rows.

Row Spacers

System Sand may be used to keep pipe in place while covering, but simple tools may also be constructed for this purpose. Two examples are shown below. One is made from rebar, the other from wood. Center-to-center row spacing tolerance is 2 in. (+/- 1 in.).

Caution: Remove all tools used as row spacers before final covering.

Two methods for spacing pipe for backfill.

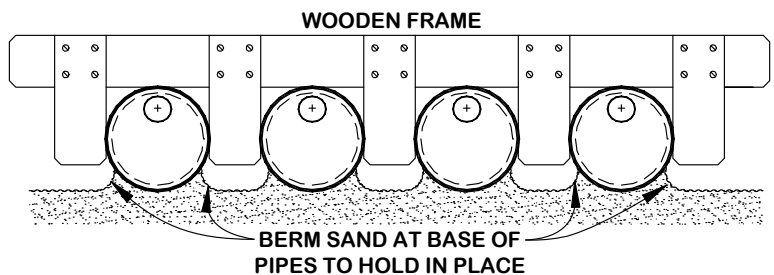
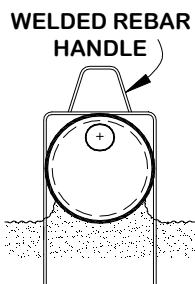

Installation Requirements, Component Handling and Site Preparation, continued

Connect Rows Using Raised Connections

Raised connections consist of offset adapters, 4 in. PVC sewer and drain pipe, and 90° elbows. They enable greater liquid storage capacity and increase the bacterial surfaces being developed. Use raised connections to connect the rows of the Advanced Enviro-Septic™ System.

Backfilling Rows

- Spread System Sand between the rows.
 - Confirm pipe rows are positioned with Bio-Accelerator™ along the bottom.
 - Straddle each row of pipe and walk heel-to-toe its entire length, ensuring that System Sand fills all void spaces beneath the Advanced Enviro-Septic™ pipe.
 - Finish spreading System Sand to the top of the rows and leave them exposed for inspection purposes.
-

Backfilling and Final Grading

Spread System Sand to a minimum of 6 in. over the pipe and a minimum of 12 in. beyond the Advanced Enviro-Septic™ pipe on all four sides.

Spread soil material free of organics, stones over 4 in. and building debris having a texture similar to the soil at the site, without causing compaction.

Note: Construction equipment should not travel over the installed system area until at least 12 in. of cover material is placed over the Advanced Enviro-Septic™ pipes (H-10 Loading). 18 in. of cover material over the Advanced Enviro-Septic™ System is required for H-20 loading. Vehicular traffic is not allowed on systems in Vermont at this time.

Fill Extensions Requirements

All Advanced Enviro-Septic™ Systems with the top of the System Sand bed above original grade require fill extensions on each side beyond the outside edge of all pipes starting at the edge of the System Sand then tapering to meet existing grade at a maximum slope of 3:1.s Steeper side slope tapering requires a waiver.

See Section I, p. 41, for System Sand and Fill Material specifications.

System Soil Cover Material

A minimum of 4 in. of suitable earth cover (topsoil or loam), with a texture similar to the soil at the site and capable of sustaining plant growth, must be placed above the installed system. Refer to Section I, System Sand and Fill Material Specifications, p. 41.

Erosion Control

To prevent erosion, soil cover above the system shall be planted with native, shallow-rooted vegetation such as grass, wildflowers and certain perennials or ground covers.

Trees and Shrubs

No trees or shrubs should be located within 10 ft. of the system perimeter to prevent roots from growing into and damaging the system.

Section N

System Bacteria Rejuvenation and Expansion

Introduction

This section covers procedures for bacteria rejuvenation and explains how to expand existing systems.

Note: Presby Environmental, Inc. must be contacted for technical assistance prior to attempting rejuvenation procedures.

Why would System Bacteria Rejuvenation be Needed?

Bacteria rejuvenation is the return of bacteria to an aerobic state. Flooding, improper venting, alteration or improper depth of soil material cover, use of incorrect sand, sudden use changes, introduction of chemicals or medicines, and a variety of other conditions can contribute to converting bacteria in any system from an aerobic to an anaerobic state. This conversion severely limits the bacteria's ability to effectively treat effluent, as well as limiting liquids from passing through. A unique feature of the Advanced Enviro-Septic™ System is its ability to be Rejuvenated in place.

How to Rejuvenate Bacteria

System bacteria are "rejuvenated" when they return to an aerobic state. By using the following procedure, this can be accomplished in most Advanced Enviro-Septic™ Systems without costly removal and replacement.

1. Contact Presby Environmental before attempting Rejuvenation for technical assistance.
 2. Determine the problem causing the bacteria conversion.
 3. Drain the system by excavating one end of all the rows and removing the offset adapters.
 4. If foreign matter has entered the system, flush the pipes.
 5. Safeguard the open excavation.
 6. Guarantee a passage of air through the system.
 7. Allow all rows to dry for a minimum of 72 hours. The System Sand should return to its natural color.
 8. Re-assemble the system to its original design configuration. As long as there is no physical damage to the Advanced Enviro-Septic™ components, the original components may be reused.
-

System Expansion

Advanced Enviro-Septic™ Systems are easily expanded by adding equal lengths of pipe to each row of the original design or by adding additional equal sections.

Note: All system expansions must comply with State and local regulations.

Local health departments must be contacted and permits obtained as required prior to Advanced Enviro-Septic™ System expansion.

Reusable Components

Advanced Enviro-Septic™ components are not biodegradable and may be reused. In cases of improper installation it may be possible to excavate, clean, and reinstall all system components.

System Replacement

If an Advanced Enviro-Septic™ System requires replacement:

- Remove the existing components and contaminated sand.
- Replace in the same excavated location with new System Sand.
- If components are not damaged, they may be flushed and reused.

Note: All system replacements must comply with State and Local regulations.

Section O

Operation & Maintenance

Proper Use

The Advanced Enviro-Septic™ Wastewater Treatment System requires minimal maintenance provided the system is not subjected to abuse. An awareness of proper use and routine maintenance will guarantee system longevity. **We encourage all system owners and service providers to obtain and review a copy of our Owner's Manual**, available from our website www.PresbyEnvironmental.com or via mail upon request to (800) 473-5298 or info@presbyeco.com.

System Abuse Conditions

The following conditions constitute system abuse:

- Liquid in high volume (excessive number of occupants, excessive use of water in a short period of time, leaking fixtures, whirlpool tubs, hot tubs, water softening equipment or additional water discharging fixtures if not specified in system design).
- Solids in high volume (excessive number of occupants, paper products, personal hygiene products, garbage disposals or water softening equipment if not specified in system design)
- Antibiotic medicines in high concentrations
- Cleaning products in high concentrations
- Fertilizers or other caustic chemicals in any amount
- Petroleum products in any amount
- Latex and oil paints
- System suffocation (compacted soils, barrier materials, etc.)

Special Note: Presby Environmental, Inc., and most regulatory agencies do not recommend the use of septic system additives.

System Maintenance/ Pumping of the Septic Tank

- Inspect the septic tank at least once every two years under normal usage.
 - Pump the tank when surface scum and bottom sludge occupy one-fourth or more of the liquid depth of the tank.
 - If a garbage disposal is used, the septic tank will likely require more frequent pumping.
 - After pumping, inspect the septic tank for integrity to ensure that no groundwater is entering it. Also check the integrity of the tank inlet and outlet baffles and repair if needed.
 - Inspect the system to ensure that vents are in place and free of obstructions.
 - Effluent filters require ongoing maintenance due to their tendency to clog and cut off oxygen to the System. Follow filter manufacturer's maintenance instructions and inspect filters frequently.
-

Site Maintenance

It is important that the system site remain free of shrubs, trees, and other woody vegetation to within a minimum of 10 ft. of the system, including the entire System Sand bed area, and areas impacted by side slope tapering and perimeter drains (if used). Roots can infiltrate and cause damage or clogging of system components.

If a perimeter drain is used, it is important to make sure that the outfall pipes are screened to prevent animal activity. Also check outfall pipes regularly to ensure that they are not obstructed in any way.

Glossary

Introduction

This Manual contains terminology which is common to the industry and terms that are unique to the Advanced Enviro-Septic™ System. While alternative definitions may exist, this section defines how these terms are used in this Manual.

Advanced Enviro-Septic™ Pipe

An Advanced Enviro-Septic™ pipe is a single unit comprised of corrugated pipe, fiber mat and fabric, 10 ft. in length, with an outside diameter of 12 in. and a storage capacity of approximately 58 gallons. Pipes joined together with couplings form a “row.” (See definition below.)

Advanced Enviro-Septic™ System

An Advanced Enviro-Septic™ System is an onsite wastewater treatment and dispersal system constructed using Advanced Enviro-Septic™ pipe in a System Sand bed that receives septic tank effluent through Basic Serial distribution, Combination Serial distribution, Distribution Box (“parallel box”) or Multiple Bed distribution.

Basic Serial Distribution

Basic Serial distribution incorporates Advanced Enviro-Septic™ rows in serial distribution in a single bed. Basic Serial distribution is described in detail on pp. 8-9.

Butterfly Configuration

A Butterfly Configuration is a variation of a standard, single bed system with the D-box located in the center, with rows oriented symmetrically on either side, and with each section receiving an equal volume of flow from the D-Box.

Center-to-Center Spacing

Center-to-center spacing is the distance from the center of one Advanced Enviro-Septic™ row to the center of the adjacent row.

Combination Serial Distribution

Combination Serial distribution incorporates two or more sections of Advanced Enviro-Septic™ in a single bed, each section receiving a maximum of 500 GPD of effluent from a distribution box. Combination Serial distribution is explained in detail on pp. 10-11.

Contour

Contour is a line connecting points of equal elevation on the surface of the earth.

Coupling

A coupling is a plastic fitting that joins two Advanced Enviro-Septic™ pipe pieces in order to form rows.

Daily Design Flow

Daily design flow is the peak daily flow of wastewater to a system, expressed in gallons per day (GPD); systems are typically sized based on the daily design flow. Design flow calculations are set forth in the Vermont Rules. How to calculate daily design flow is explained on p. 27. In general, actual daily use is expected to be one-half to two-thirds less than “daily design flow.”

Glossary, continued

Differential Venting	<u>Differential venting</u> is a method of venting an Advanced Enviro-Septic™ System utilizing high and low vents. Venting requirements are described in detail in Section K, Venting Requirements, pp. 44-48.
Distribution Box or “D-Box”	A <u>distribution box</u> (also called a “D-Box”) is a device designed to distribute effluent from the septic tank equally to each of the outlet pipes that carry effluent into the Advanced Enviro-Septic™ System.
D-Box Distribution Configuration	A <u>D-Box distribution configuration</u> is a design in which each Advanced Enviro-Septic™ row receives effluent from a distribution box outlet. Such a system is also sometimes called a “parallel system” or a “finger system.” See page _____.
Distribution Box Manifold	A <u>distribution box manifold</u> is a PVC configuration which connects several distribution box outlets together in order to equalize effluent flow. Refer to drawing on p. 22.
Double Offset Adaptor	A <u>double offset adaptor</u> is a plastic fitting with two 4 in. offset holes installed at the 6 o'clock and 12 o'clock positions. The holes allow for connections from one row to another and for installation of ventilation and bottom drains (if used).
Drop Connection	A <u>drop connection</u> is a piece of 4 in. PVC pipe connecting two levels of Advanced Enviro-Septic™ pipe. Drop Connections are only used in Multi-Level™ systems.
End-to-End Configuration	An <u>end-to-end bed configuration</u> consists of two or more beds constructed in a line (i.e., aligned along the width of the beds).
Fill Extension	<u>Fill Extensions</u> are utilized in constructing above ground systems and blend the raised portion of the system with side slope tapering to meet existing grade. In systems sloping up to 10%, the fill extensions extend 3 ft. on all sides. In systems sloping more than 10%, the fill extension is increased to 5 ft. on the downslope side.
Fill Material	<u>Fill material</u> is soil material with specific textural criteria as set forth in the Vermont Rules that is used in the process of system construction and/or to enhance surface water diversion. Complete information about fill requirements can be found in Section I, System Sand and Fill Material Specifications, p. 41.
Flow Equalizer	A <u>flow equalizer</u> is an adjustable plastic insert installed in the outlet pipes of a distribution box to equalize effluent distribution to each outlet.

Glossary, continued

GPD	<u>GPD</u> is an acronym for <u>G</u> allons <u>P</u> er <u>D</u> ay.
GPM	<u>GPM</u> is an acronym for <u>G</u> allons <u>P</u> er <u>M</u> inute.
High and Low Vents	<u>High and low vents</u> are pipes used in differential venting. Detailed information about venting requirements can be found in Section K, pp. 44-48.
High Flow	<u>High flow</u> is a daily design flow of more than 900 GPD.
Infiltrative Surface	<u>Infiltrative surface</u> is the surface used for the absorption of treated wastewater by the soil. This is the interface between the System Sand or Sand Fill and the prepared soil.
Low Flow	<u>Low Flow</u> is daily design flow of 900 GPD or less.
MPI	<u>MPI</u> is an acronym for <u>M</u> inutes <u>P</u> er <u>I</u> nch and is the numerical value by which percolation rates (also called “perc. rates”) are expressed.
Multi-Level™	A Multi-Level™ System is a patented process using Advanced Enviro-Septic™ pipe; it consists of essentially two Advanced Enviro-Septic™ Systems installed in the same bed with one system on top of another with 6 in. of System Sand between the two levels. Multi-Level™ Systems are not yet approved for use in Vermont without a waiver. Contact Presby Environmental for design criteria.
Multiple Bed Distribution	<u>Multiple bed distribution</u> incorporates two or more beds, each bed with Basic Serial or Combination Serial distribution and receiving effluent from a distribution box. Multiple Bed distribution is described on pp. 12-15.
Non-Conventional Configurations	<u>Non-conventional configurations</u> have irregular shapes, or row lengths shorter than 30 ft. or longer than 100 ft., in order to accommodate site constraints. Non-conventional configurations are described in detail on pp. 19-21.
Offset Adapter	An <u>offset adapter</u> is a plastic fitting with a 4 in. hole installed at the 12 o'clock position which allows for connections from one row to another and for installation of venting.
Percolation Rate “Perc. Rate”	<u>Percolation Rate</u> , or <u>Perc. Rate</u> , is a numerical indication of a soil's hydraulic capacity, expressed in minutes per inch (MPI.)

Glossary, continued

Pressure Distribution

Pressure Distribution is a pressurized, small-diameter pipe system used to deliver effluent to an absorption field. **Pressure Distribution is not permitted to be used with the Advanced Enviro-Septic™ System.** The Advanced Enviro-Septic™ System is designed to promote even distribution without the need for pressure distribution.

Pump Systems

Pump Systems utilize a pump to gain elevation in order to deliver effluent to a distribution box. Detailed information about pump systems can be found in Section J, Pump System Requirements, pp. 42-43.

Raised Connection

A raised connection is a U-shaped PVC Sewer & Drain (S&D) pipe configuration which is used to connect rows oriented in a serial configuration and to maintain the proper liquid level inside each row. See drawing in Section B, Advanced Enviro-Septic™ Components, pp. 4-5.

Raised Straight Connection

A raised straight connection is a PVC Sewer & Drain (S&D) pipe arrangement used to connect rows in a Non-Conventional system or In-Line configuration which is oriented along the contour of the site to maintain the proper liquid level inside each row. See drawing in Section B, Advanced Enviro-Septic™ Components, pp. 4-5.

Raking and Tilling

Raking and tilling refers to methods of preparing the native soil that will be covered with System Sand or Sand Fill, creating a transitional layer between the sand and the soil. Detailed information about raking and tilling procedures can be found in Section M, Installation Requirements, Component Handling and Site Preparation, pp. 50-53.

Required Offset

Required offset refers to the required minimum separation distance to groundwater or other restrictive soil features.

Row

A row consists of a number of Advanced Enviro-Septic™ pipe sections connected by couplings with an offset adapter on the inlet end and an offset adapter or double offset adaptor on the opposite end. Rows are typically between 30 ft. and 100 ft. long. Minimum row length is 65 ft. in soils with perc rates from 51-60 MPI.

Sand Fill

Sand fill is clean sand, free of organic materials and meeting the specifications set forth in Section I, System Sand and Fill Material Specifications, p. 41. Sand fill is used to raise the elevation of the system to meet required separation distance or in side slope tapers. System Sand may be used in place of Sand Fill.

Section

A section is a group of interconnected rows receiving effluent from one distribution box outlet.

Serial Distribution

Serial distribution is two or more Advanced Enviro-Septic™ rows connected by a raised connection. Basic Serial distribution is described in detail on pp. 8-9, Combination Serial distribution is described in detail on pp.10-11.

Glossary, Continued

SHWT SHWT is an acronym for Seasonal High Water Table.

Side-to-Side Configuration Side-to-side bed configurations consist of two or more beds arranged so that the rows are parallel to one another.

Slope Slope, expressed as a **ratio**, is a quotient of the horizontal distance and the difference in elevation between two points on the surface of a landform. In this Manual, slope is expressed as a ratio of run to rise.

Example: A slope with a grade of three to one (3:1) is the difference in horizontal distance of three (3) horizontal feet (run) over an elevation difference of one (1) ft. (rise).

Slope, expressed as a **percent**, is the difference in elevation divided by the difference in horizontal distance between two points on the surface of a landform.

Example: A site slope of one (1) percent is the difference in elevation of one (1) foot (rise) over a horizontal distance of one hundred (100) feet (run).

Smearing Smearing is the mechanical sealing of soil air spaces along an excavated, tilled or compressed surface. This is also referred to as “compacting.” In all installations, it is **critical** to avoid smearing or compacting the soils under and around the Advanced Enviro-Septic™ System.

Soil Soil is naturally-occurring mineral and/or organic matter found on the surface of the system site.

Surface Diversion A surface diversion is a natural or manmade barrier that changes the course of surface flow of water around an onsite system’s soil absorption field.

System Sand Bed The System Sand bed is the minimum System Sand area required in Advanced Enviro-Septic™ Systems. The System Sand bed extends a minimum of 6 in. below, 6 in. above and 12 in. horizontally from the outside edges of the pipes in the system.

System Sand Extension Area The System Sand extension area is additional System Sand added to the down slope side of all systems sloping more than 10%. The System Sand extension area is a minimum of 6 in. deep and extends a minimum of 3 ft. beyond the down slope edge of the System Sand bed.

Topsoil (a.k.a. Loam or Soil Cover Material) Topsoil, also known as Loam, is soil material cover capable of sustaining plant growth which forms the topmost layer of cover material above the system. Detailed information about soil cover requirements is found in Section I, System Sand and Fill Material Specifications, p. 41.

Velocity Reducer Velocity reducer refers to any of the various components whose purpose is to reduce the velocity of effluent flow into the Advanced Enviro-Septic™ pipes. A distribution box with a baffle or inlet tee is sufficient for velocity reduction in most systems. See Section E, General Design Criteria, “Velocity Reduction,” p. 26.



Appendix A – VT Advanced Enviro-Septic™ System Installation Form

Installers must complete and fax or mail a copy of this form to the local approving authority and to: **Presby Environmental, Inc., 143 Airport Rd, Whitefield, NH 03598**
Fax: (603) 837-9864

Installer's Name:		Installer's PEI Certification Number:	
Company Name:			
Street Address:			
City:		State:	Zip:
Installer's Phone Number:			
Designer's Name:		Company Name:	
Street Address:			
City:		State:	Zip:
Phone Number:			
Property Owner(s):			
Site Street Address:			
City:		State:	Zip:
System Information <i>(check all that apply):</i>			
<input type="checkbox"/> New Construction <input type="checkbox"/> Replacement <input type="checkbox"/> Mound <input type="checkbox"/> In ground <input type="checkbox"/> Gravity			
<input type="checkbox"/> Pump to D-Box <input type="checkbox"/> Serial Distribution Number of Beds: _____			
<input type="checkbox"/> Effluent Filter Used Design Flow (bedrooms or gpd): _____			
Installation Date:		System Startup Date:	
Local Construction Permit Number:			
Comments:			

Advanced Enviro-Septic™ (AES) Treatment Systems Configuration Options & Comparisons

Please Note: Advanced Enviro-Septic™ pipe from Presby Environmental is utilized in both NSF Standard 40 Models and in site-specific designs as allowed by State and/or Local approving authorities. NSF-40 testing of AES confirms effluent treatment and system reliability; however, State and/or Local regulations govern infiltration design considerations. The virtually unlimited design options of AES pipe made it impractical to submit all possible system configurations to NSF-40 testing protocols for Certification. The summary below highlights the major differences between AES Systems designed in accordance with State and/or Local regulations for a specific site and NSF-40 Certified Models constructed with AES pipe.

 <p>Advanced Enviro-Septic™ Systems per State/Local Approvals</p> <p>(Visit website for current State Approvals: PresbyEnvironmental.com)</p>	 <p>NSF Standard 40 Class I Certified Advanced Enviro-Septic™ Systems Certificate No. 3U460-0 Issued 09/22/09</p>
<p>State-Specific Configurations:</p> <p>No “models,” site-specific designs by Certified Designers as approved by State or Local approving authorities</p> <p>Can be designed to accommodate any hydraulic design flow from 300 gallons per day up</p> <p>Bed or Trench sizes per State regulations</p> <p>All systems provide combined treatment and dispersal into underlying soils</p>	<p>NSF-40 Certified Models Available:</p> <p>CTD* 450 & SPD[□] 450 (three (3) bedroom) CTD* 600 & SPD[□] 600 (four (4) bedroom) CTD* 750 & SPD[□] 750 (five (5) bedroom) CTD* 900 & SPD[□] 900 (six (6) bedroom) CTD* 1050 & SPD[□] 1050 (seven (7) bedroom) CTD* 1200 & SPD[□] 1200 (eight (8) bedroom) CTD* 1350 & SPD[□] 1350 (nine (9) bedroom) CTD* 1500 & SPD[□] 1500 (ten (10) bedroom)</p> <p><small>* CTD Models are “bottomless” and provide combined treatment and dispersal [□] SPD Models are constructed within an impermeable geomembrane liner, separate dispersal system required</small></p>
<p>Components and AES pipe sold separately Replacement systems can use existing septic tank if structurally sound No maintenance contract required</p>	<p>“System” must be purchased as a “package” that includes AES pipe, all required components (including septic tank, alarm, sampling port, distribution box, and geomembrane liner for SPD models) and a mandatory two-year pre-paid maintenance contract.</p>
<p>Trained/Certified Network of Designers and Installers; product available through local dealers/distributors</p>	<p>Available only through Authorized Representatives trained by Presby Environmental</p>
<p>Does not require electricity or alarms; some states require sampling/observation/inspection ports</p>	<p>Requires electricity, high water alarm, and sampling device</p>
<p>Systems can be designed in unique shapes (trapezoid, curved, angled, etc.) to adapt to site’s topography and constraints. Can be used in bed or trench configurations Basic Serial, Combination, Multiple-bed and Distribution Box configurations</p>	<p>Systems are rectangular and installed in bed format using Distribution Box (“Parallel”) Configuration only</p>
<p>Systems can be installed level or sloping (maximum site slope 33%, maximum system slope 25%, or as permitted by State approvals)</p>	<p>Systems must be installed level to within +/-½ inch</p>
<p>Component labels do not bear the NSF logo</p>	<p>Component labels bear the NSF logo</p>
<p>Residential, Commercial and Community applications (varies by State)</p>	<p>Residential Use ONLY</p>
<p>This Manual provides information specific to the use of Advanced Enviro-Septic™ per State Approval. Please check our website for current State approvals: PresbyEnvironmental.com</p>	<p>NSF-40 Certified Models utilize a distinct Installation Manual available only to Authorized Representatives of Presby Environmental. Please call Customer Service at (800) 473-5298 for more information.</p>