

# Enviro-Septic® Wastewater Treatment System Massachusetts Design and Installation Manual



**PRESBY ENVIRONMENTAL, INC.**  
*INNOVATIVE SEPTIC TECHNOLOGIES*

143 Airport Road, Whitefield, NH 03598  
Tel: 1-800-473-5298 Fax: (603) 837-9864

Updated March 2011

# Enviro-Septic® Wastewater Treatment System Massachusetts Design and Installation Manual

## Preview

### Background

Liquid that exits from a septic tank (effluent) contains suspended solids that cause other types of leaching systems to fail. Solids overload bacteria, cut off aeration required for bacterial activity, and seal the underlying soil.

### System components

Here's a picture of the Enviro-Septic® system components.

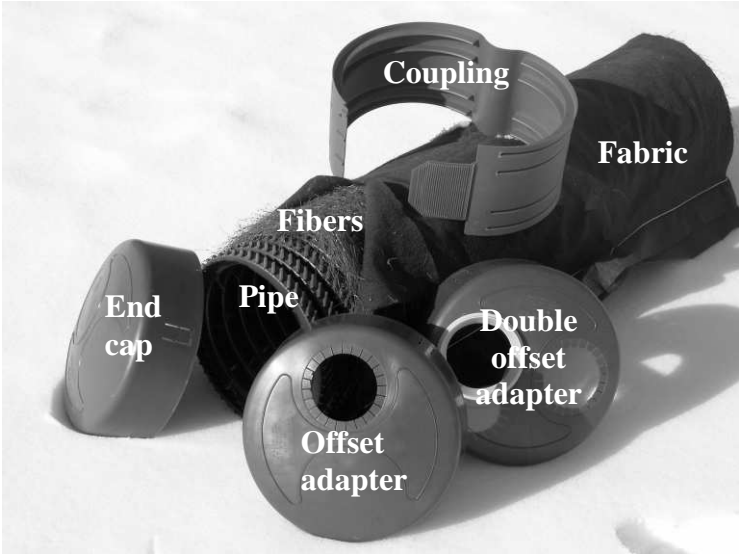

### What our system does

By utilizing simple, yet effective natural processes, the Enviro-Septic® wastewater treatment system treats septic tank effluent in a manner that prevents solids from entering surrounding soils, increases system aeration, and provides a greater bacterial area (biomat) than traditional systems.

### Why our system excels

The Enviro-Septic® wastewater treatment system retains solids in its pipe and provides multiple bacterial surfaces to treat effluent prior to its contact with the soil. The continual cycling of effluent (the rising and falling of liquid inside the pipe) enhances bacterial growth. No other design offers this functionality. Our systems excel because they are more efficient, last longer, and have a minimal environmental impact.

*Continued*

# Preview, Continued

## Pipe section diagram

Here's a cross section diagram of Enviro-Septic<sup>®</sup> pipe.

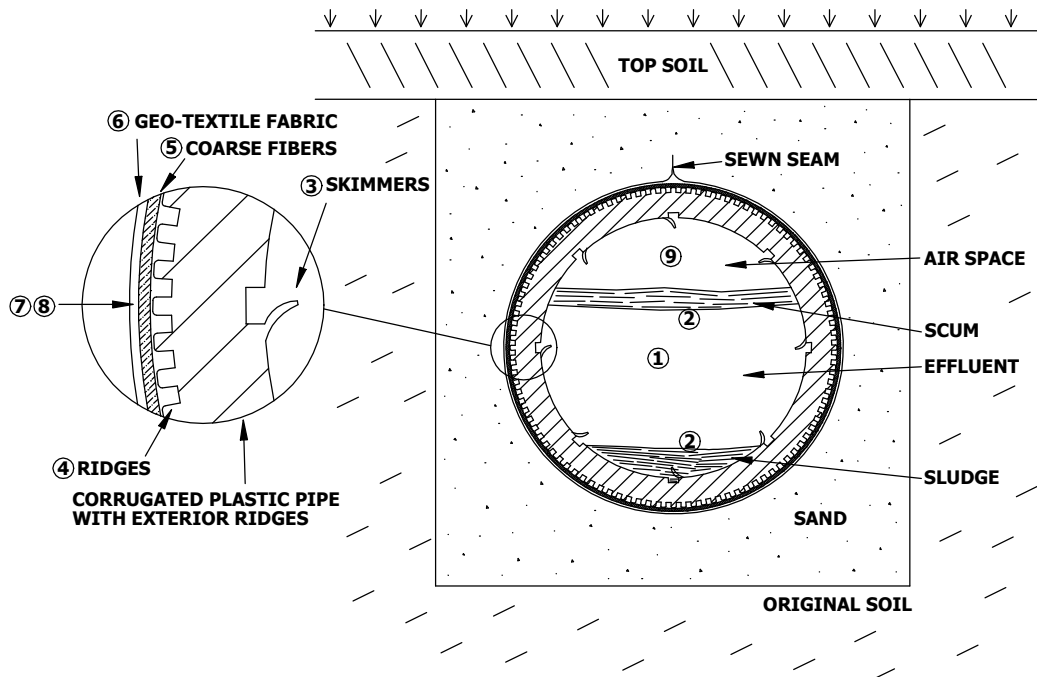

## How it works

These are the nine stages in the Enviro-Septic<sup>®</sup> wastewater treatment system.

Stage	What Happens
1	Warm effluent enters the pipe and is cooled to ground temperature.
2	Suspended solids separate from the cooled liquid effluent.
3	Skimmers further capture grease and suspended solids from the effluent as it exits through perforations in the pipe.
4	Pipe ridges allow the effluent to flow uninterrupted around the circumference of the pipe and aid in cooling.
5	A mat of random, coarse fibers separates more suspended solids from the effluent.
6	Effluent passes into the geo-textile fabric and grows a protected bacterial surface.
7	Sand wicks the liquid from the geo-textile fabric and enables air to transfer to the bacterial surface.
8	Fabric and fibers provide a large bacterial surface to break down solids.
9	An ample air supply and fluctuating liquid levels increase bacterial efficiency.

*Continued*

## Preview, Continued

### System advantages

An Enviro-Septic<sup>®</sup> wastewater treatment system

- costs less than traditional installation products and materials
- requires a smaller area
- blends into sloping terrain
- adapts to difficult sites
- installs more easily and quickly than traditional systems
- eliminates the need for expensive washed stone
- adapts easily to both commercial and residential sites
- uses a protected receiving surface
- increases system performance and longevity
- tests environmentally safer than conventional systems
- recharges groundwater more safely than conventional systems

### In this manual

This manual contains the following sections.

<b>Section</b>	<b>Page</b>
A – Introduction	4
B – Definitions of Terms	5
C – Design Criteria, Requirements, and Restrictions	9
D – Title 5 and Aggregate Systems Exceptions	14
E – Installation, Handling, and Storage Guidelines	16
F – System Sand Requirements	19
G – Standard System Configurations	20
H – Non-Standard System Configurations	31
I – Pump System Requirements	33
J – Venting Requirements	34
K – Inspection Port Requirements	36
L – Bottom Drains and Requirements	37
M – System Rejuvenation and Expansion	38
N – Quick Reference Guide for Percolation Rates Up to 60 Minutes/Inch	39
O – Quick Reference Guide for Percolation Rates of 61-90 Minutes/Inch	44
System Installation Form	Appendix A
Enviro-Septic <sup>®</sup> Wastewater Treatment System Technology Checklist	Appendix B
Massachusetts DEP Operation & Maintenance Annual Inspection form	Appendix C
Enviro-Septic <sup>®</sup> Wastewater Treatment System Operating Manual	Appendix D

## Section A Introduction

---

<b>Purpose</b>	The purpose of this manual is to provide guidance in the design and installation of the Presby Environmental, Inc., Enviro-Septic <sup>®</sup> wastewater treatment system products.
<b>Presby Environmental, Inc., standards</b>	All systems using Presby Environmental, Inc., Enviro-Septic <sup>®</sup> wastewater treatment system products must be designed and installed in compliance with the procedures and specifications described in this manual.
<b>State standards</b>	Title 5, 310 CMR 15.000, the State Environmental Code for Massachusetts covers issues not addressed in this manual. Title 5 requirements take precedence unless specifically changed by the General Use or Remedial Use approvals issued for the Enviro-Septic <sup>®</sup> system.
<b>Certification required</b>	<p>MassDEP and Presby Environmental, Inc., require all designers and installers to be certified. Certification is obtained by attending the “Enviro-Septic<sup>®</sup> Designer and Installer Certification Course” presented by Presby Environmental, Inc., or its sanctioned representatives.</p> <p>Until designers and installers are certified, designs and installations must be approved/inspected by Presby Environmental, Inc., or its sanctioned representatives.</p> <p><u>Special Note:</u> Presby Environmental, Inc., recommends that all individuals involved in the approval or permitting process also attend these sessions.</p>
<b>“System Installation Form” required</b>	<p>Installers of Enviro-Septic<sup>®</sup> systems shall provide Presby Environmental, Inc., and the local approving authority with a copy of a completed “System Installation Form” for each new or remedial system installed.</p> <p><u>Reference:</u> See “Appendix A – System Installation Form.”</p>
<b>Technical support</b>	Presby Environmental, Inc., provides technical support to all individuals using our products. For questions about the information contained in this manual, please review our website at <a href="http://www.presbyenvironmental.com">www.presbyenvironmental.com</a> or contact us at 1-800-473-5298.

---

## Section B

### Definitions of Terms

---

**Introduction** This section defines terms as they are used in this manual.

---

**List of terms** Here's a list of the terms defined in this section.

- Basic serial system
- Bed
- Bottom drain
- Center-to-center spacing
- Combination serial system
- Coupling
- D-Box
- Design flow
- Differential venting
- Distribution box
- Distribution box manifold
- Distribution box system
- Double offset adapter
- Drain sump
- EHGW
- End cap
- Enviro-Septic<sup>®</sup> pipe
- Flow equalizer
- GPD
- High and low vents
- High flow
- Inground system
- Level system
- Line
- Low flow
- Multiple bed system
- Offset adapter
- Raised connection
- Raised system
- Section
- Serial distribution
- Slope
- Sloping system
- Smear
- Surrounding sand
- System sand

---

*Continued*

## Definitions of Terms, Continued

---

<b>Basic serial system</b>	A <u>basic serial system</u> is a system consisting of one bed of Enviro-Septic <sup>®</sup> pipe in serial configuration.
<b>Bed</b>	A <u>bed</u> is 2 or more lines of Enviro-Septic <sup>®</sup> pipe located within a contiguous inground or raised system sand bed area.
<b>Bottom drain</b>	A <u>bottom drain</u> is a sealed pipe connecting the end of a basic serial system, the ends of all distribution box system lines, or the end of each section of a combination serial system to a sealed drain.
<b>Center-to-center spacing</b>	<u>Center-to-center spacing</u> is the horizontal distance from the center of one line to the center of the adjacent line.
<b>Combination serial system</b>	A <u>combination serial system</u> is a system incorporating two or more sections of Enviro-Septic <sup>®</sup> pipe in serial configuration, each section receiving effluent from a distribution box.
<b>Coupling</b>	A <u>coupling</u> is a fitting that joins two pieces of Enviro-Septic <sup>®</sup> pipe.
<b>D-Box</b>	<u>D-Box</u> is an abbreviation for distribution box.
<b>Design flow</b>	<u>Design flow</u> is the assigned peak daily flow of sewage, in gallons per day, from a residence or commercial facility.
<b>Differential venting</b>	<u>Differential venting</u> is a method of venting an Enviro-Septic <sup>®</sup> system using high and low vents.
<b>Distribution box</b>	A <u>distribution box</u> is a device used to divide and/or control effluent flow.
<b>Distribution box manifold</b>	A <u>distribution box manifold</u> is a method of joining any number of distribution box outlets to a single pipe.
<b>Distribution box system</b>	A <u>distribution box system</u> is a number of Enviro-Septic <sup>®</sup> lines of equal length, each supplied evenly with effluent through a distribution box.
<b>Double offset adapter</b>	A <u>double offset adapter</u> is an end cap with a two 4" offset holes. Double offset adapters are used in bottom drain installations.

*Continued*

## Definitions of Terms, Continued

---

<b>Drain sump</b>	A <u>drain sump</u> is a watertight chamber connected to the end of a bottom drain line.  <u>Reference:</u> See Section L, “Bottom Drains and Requirements,” p. 37.
<b>EHGW</b>	<u>EHGW</u> is an abbreviation for estimated high ground-water elevations.
<b>End cap</b>	An <u>end cap</u> is a cap used at the end of an Enviro-Septic <sup>®</sup> line or section.
<b>Enviro-Septic<sup>®</sup> pipe</b>	An <u>Enviro-Septic<sup>®</sup> pipe</u> is a single unit of pipe, 10’ in length with an outside diameter of 12” and a storage capacity of approximately 58 gallons.
<b>Flow equalizer</b>	A <u>flow equalizer</u> is an insert installed in each outlet of a distribution box to equalize the effluent distribution for multiple outlets.
<b>GPD</b>	<u>GPD</u> is an abbreviation for gallons per day.
<b>High and low vents</b>	<u>High and low vents</u> are pipe components used in all systems to ensure that air is drawn completely through the entire Enviro-Septic <sup>®</sup> system.
<b>High flow</b>	<u>High flow</u> is a “design daily flow” greater than 500 GPD. High flows require combination or distribution box system designs or multiple serial beds.
<b>Inground system</b>	An <u>inground system</u> is a system installed with the bottom of the system sand bed below the existing grade.
<b>Level system</b>	A <u>level system</u> is a system in which lines of Enviro-Septic <sup>®</sup> are installed at the same elevation.
<b>Line</b>	A <u>line</u> is a number of Enviro-Septic <sup>®</sup> pipes connected by couplings with an offset adapter on the inlet end and an offset adapter on the opposite end.
<b>Low flow</b>	<u>Low flow</u> is a “design daily flow” of 500 GPD or less. Basic serial system configuration is preferred for low flow systems.
<b>Multiple bed System</b>	A <u>multiple bed system</u> incorporates two or more beds, each bed with basic serial or combination serial distribution and receiving effluent from a distribution box.

---

*Continued*

## Definitions of Terms, Continued

---

<b>Offset adapter</b>	An <u>offset adapter</u> is an end cap with a 4” offset hole. Offset adapters are used for raised connections, venting and system inlets.
<b>Raised connection</b>	A <u>raised connection</u> is an arrangement of sewer and drain PVC pipe used to connect lines of Enviro-Septic <sup>®</sup> pipe to maintain the correct liquid level inside each line.
<b>Raised system</b>	A <u>raised system</u> is a system installed with the bottom of the system sand bed at or above the existing grade.
<b>Section</b>	A <u>section</u> is a group of Enviro-Septic <sup>®</sup> lines in serial distribution receiving effluent from a distribution box in a combination system.
<b>Serial distribution</b>	A <u>serial distribution</u> is a group of Enviro-Septic <sup>®</sup> lines connected with a raised connection.  <u>Reference:</u> See “line,” p. 7.
<b>Slope</b>	<u>Slope</u> is the ratio of the difference in elevation and the difference in horizontal distance between two points on the surface of a landform expressed as a percent, and commonly stated as rise over run.  <u>Example:</u> A slope of one percent is the difference in elevation of one foot (rise) over a horizontal distance of one hundred feet (run).
<b>Sloping system</b>	A <u>sloping system</u> is a system in which lines of Enviro-Septic <sup>®</sup> are installed in decreasing elevations.
<b>Smear</b>	To <u>smear</u> is to mechanically seal the natural pores of soil along an excavated or tilled surface.
<b>Surrounding sand</b>	<u>Surrounding sand</u> is the sand/soil material adjacent to the system sand.  <u>Reference:</u> See specifications, “Section F – System Sand Requirements,” p. 19.
<b>System Sand</b>	<u>System sand</u> is the sand immediately surrounding the Enviro-Septic <sup>®</sup> pipe and is required in all Enviro-Septic <sup>®</sup> installations.  <u>Reference:</u> See specifications, “Section F – System Sand Requirements,” p. 19.

---

## Section C

### Design Criteria, Requirements, and Restrictions

---

**Introduction** This section contains a variety of criteria, requirements, and restrictions for designing Enviro-Septic<sup>®</sup> wastewater treatment systems.

---

**Subjects covered** This table contains the subjects covered and the page location of each.

Subject	Page
Access recommended	9
Distribution Box requirements	9
Depth of cover	10
Design flow	10
Designer documentation required	10
High flow system configurations	10
Inspection port required	10
Line elevations	10
Line orientation	10
Loading limits	10
Longer lines preferable	10
Low flow system configuration	10
Maximum/minimum line lengths	11
Minimum separation distances	11
New construction sizing	11
Non-standard design requirements	11
Percolation rate restriction	11
Pressure distribution lines	11
Pumps used to gain elevation	11
Raised (Mounds) systems minimum fill extensions	12
Remedial bed design restrictions – 61-90 percolation rates	12
Reserve area	12
Soil moisture construction limitation	12
System Installation Form	12
System size limitation	12
Ten foot increments work best	12
Venting requirements	13
Wastewater strength	13

---

**Access recommended** Installations under paved or inaccessible locations are recommended to be designed with access to one end of all lines or designed and installed with bottom drains. Such features facilitate system rejuvenation.

---

**D-Box requirements** All systems shall be designed and installed using distribution boxes. The outlet of the distribution box shall be at least 2” above the inlet of the highest Enviro-Septic<sup>®</sup> line with the connecting pipe slope not less than 2%.

---

*Continued*

## Design Criteria, Requirements, and Restrictions, Continued

---

<b>Depth of cover</b>	The minimum total depth of cover on Enviro-Septic® lines is 10 inches: 6” of system sand plus 4” of topsoil. Enviro-Septic® pipe with 12” of structural cover is designed for H-10 loading, and Enviro-Septic® pipe with 18” of structural cover is designed for H-20 loading.
<b>Design flow</b>	Design flow is defined in Title 5, 310 CMR 15.002. Design flow criteria are presented in 310 CMR 15.203  When design flow is not established in 310 CMR 15.203, water meter readings can be used in accordance with 310 CMR 15.203 (6). For residential systems, design flows below 330 gallons per day require a variance.
<b>Designer documentation required</b>	The designer must provide the system owner with copies of the State’s Certification for General Use and/or Approval for Remedial Use and an “Enviro-Septic® Wastewater Treatment Operating Manual,” and a “Technology Checklist.”  <u>Reference:</u> See “Appendix B, Technology Checklist.”
<b>High flow system configurations</b>	High flow is a “design flow” greater than 500 GPD. High flows in soils with perc rates of up to 60 min/inch require combination or distribution box system configurations or multiple serial beds. All high flow systems in soils with perc rates of 61-90 min/inch require multiple serial beds.
<b>Inspection Port required</b>	All systems require an inspection port. See Section K , Inspection Port Requirements, p. 36.
<b>Line elevations</b>	For sloping systems it is helpful to provide elevations on the design for each line of the system.
<b>Line orientation</b>	Enviro-Septic® lines must be laid level and should run parallel to contours (perpendicular to sloping terrain).
<b>Loading limits</b>	Each basic serial bed, line of a distribution box system, and section of a combination system has a maximum limit design daily flow of 500 GPD.
<b>Longer lines preferable</b>	All systems should be designed and installed as long and narrow as possible for the site, with the system length perpendicular to the slope of the natural soil, which is usually parallel to the existing site contour.
<b>Low flow system configuration</b>	Low flow is a “design flow” of 500 GPD or less. Basic serial system configuration is preferred for low flow systems.

---

*Continued*

## Design Criteria, Requirements, and Restrictions, Continued

---

**Maximum/minimum line lengths** No single line of any system may exceed 100' or be less than 30' in length, but the multiple lines of a basic serial system or section of a combination system may total more than 100' in length when connected in series using raised connections.

Note: In some instances site conditions may require lines shorter than 30' or systems longer than 100'. These are non-standard system configurations.

Reference: See "Section H – Non-Standard System Configurations," p. 31.

---

**Minimum separation distances** Setback distances are measured from the outer edge of the required system sand. The distances to the estimated high groundwater elevation (EHGW) and other restrictive features are measured from the bottom of the 6" of system sand below the bottom of the Enviro-Septic<sup>®</sup> pipe.

Reference: See "Section D – Title 5 and Aggregate Systems Exceptions," p. 14.

---

**New construction sizing** For new construction, the system owner initially shall size a soil absorption system in accordance with 310 CMR 15.242 to demonstrate that a conventional Title 5 soil absorption system using aggregate, including a reserve area, can be installed on the site. The system owner may then size the soil absorption system for the Enviro-Septic<sup>®</sup> system.

---

**Non-standard design requirements** Designers shall include on all non-standard system configuration plans, a statement that Presby Environmental, Inc., will not be responsible for systems designed or installed that do not meet the standards established by these procedures and specifications.

---

**Percolation rate restriction** General use systems are limited to sites with a percolation rate of up to 60 min/inch. Remedial systems can be constructed where the percolation rate is up to 90 min/inch.

---

**Pressure distribution lines** **The use of pressure distribution lines in Enviro-Septic<sup>®</sup> wastewater treatment systems is prohibited.**

---

**Pumps used to gain elevation** Systems incorporating pumps to gain elevation must use differential venting and velocity reduction to control liquid flow. Velocity reduction may be accomplished through the use of a distribution box with a tee or 90° elbow at the force main outlet.

References: See "Section I - Pump System Requirements" p. 33 and "Section J – Venting Requirements," p. 34.

Special Note: **The use of pressure distribution lines in Enviro-Septic<sup>®</sup> wastewater treatment systems is prohibited.**

---

*Continued*

## Design Criteria, Requirements, and Restrictions, Continued

---

<b>Raised (Mounds) systems minimum fill extensions</b>	<p><b>All mounded systems shall be designed and constructed in accordance with 310 CMR 15.255.</b> Raised Enviro-Septic<sup>®</sup> systems are designed for sites with soil or depth constraints that do not allow inground configurations</p> <p>Topsoil is required around the fill perimeter of raised systems.</p> <p><u>Note:</u> All mounded systems shall be designed and constructed in accordance with 310 CMR 15.255.</p> <p><u>Reference:</u> See detailed diagrams, pp.29-30.</p>
<b>Remedial bed design restrictions – 61-90 percolation rates</b>	<p>Remedial systems in soils with percolation rates greater than 60 and up to 90 minutes per inch must be designed as basic serial systems. A multiple bed system uses a distribution box with flow equalizers. No bed in a multiple bed system can have a design flow of more than 500 GPD. Beds shall be separated by at least six feet of naturally occurring undisturbed soil. To accommodate construction access, additional separation distance may be necessary.</p>
<b>Reserve area</b>	<p>For new construction a system must contain a reserve area the size of a conventional Title 5 soil absorption system using aggregate. For Remedial systems the system owner must demonstrate that sufficient reserve is not available so that the system can be designed without a reserve area.</p>
<b>Soil moisture construction limitation</b>	<p>If a fragment of soil from about 9” below the surface can easily be rolled into a wire, the soil moisture content is too high for construction.</p>
<b>System Installation Form</b>	<p>Installers of Enviro-Septic<sup>®</sup> systems shall provide Presby Environmental, Inc., and the approving authority with a copy of a completed “System Installation Form” for each new or replacement system installed.</p> <p><u>Reference:</u> See “Appendix A – System Installation Form.”</p>
<b>System size limitation</b>	<p>To meet Massachusetts’ requirements, at no time may an Enviro-Septic<sup>®</sup> system be designed to have a sand bed area less than 60% of a conventional Title 5 aggregate system designed in accordance with 310 CMR 15.252 for the same site. In addition, the minimum area for a system installed for new construction shall be 400 square feet.</p>
<b>Ten foot increments work best</b>	<p>It is easier if line lengths are designed in exact 10’ increments since Enviro-Septic<sup>®</sup> pipe is 10’ in length. However, if necessary, the pipe is easily cut to meet site constraints.</p>

*Continued*

## Design Criteria, Requirements, and Restrictions, Continued

---

**Venting requirements**

Each Enviro-Septic<sup>®</sup> system must be installed with venting at the end of each distribution box line, section, or serial bed. Vent manifolds may be used to connect multiple vents to one vent outlet.

---

**Wastewater strength**

Where wastewater strength exceeds typical human sewage waste, additional Enviro-Septic<sup>®</sup> pipe is required. In some cases additional sand bed area will be required to accommodate the additional pipe. Should designers identify high wastewater strength and need assistance, they may consult Presby Environmental, Inc.

---

## Section D

### Title 5 and Aggregate Systems Exceptions

---

<b>Introduction</b>	Due to the unique capabilities of Enviro-Septic <sup>®</sup> systems, some Title 5 and other requirements commonly associated with aggregate systems do not apply. This page presents some of the more common exceptions.
<b>No septic tank tee filters</b>	Effluent tee filters will not be required for septic tanks used in Enviro-Septic <sup>®</sup> systems.
<b>Serial distribution allowed</b>	Lines of Enviro-Septic <sup>®</sup> pipe may be installed in serial configuration for flows of up to 500 GPD per basic serial bed or combination section.
<b>No pressure distribution</b>	<b>Pressure distribution may not be used with any Enviro-Septic<sup>®</sup> system, including systems that are designed for over 2000 GPD.</b>
<b>Restaurants/grease traps</b>	Enviro-Septic <sup>®</sup> systems may be used for restaurants and other facilities that use grease traps.
<b>New construction provisions</b>	<p>These are provisions for new construction.</p> <p><u>Reduced area size</u> Enviro-Septic<sup>®</sup> systems may be installed in an area up to 40% smaller than a conventional Title 5 bed designed in accordance with 310 CMR 15.252.</p> <p><u>Note:</u> The system sizing tables used in this manual identify minimum Enviro-Septic<sup>®</sup> requirements reflecting this reduction.</p> <p><u>Reduction Limitation:</u> Currently Massachusetts limits all systems to a minimum bed size of 400 square feet.</p>

---

*Continued*

## Title 5 and Aggregate Systems Exceptions Continued

---

**New  
construction  
provisions  
(continued)**

Minimum vertical separation distances to EHGW

In soils with percolation rates of 2 min/in or less the minimum vertical separation distance to the EHGW is 5' measured from the required 6" of system sand at the bottom of the Enviro-Septic<sup>®</sup> pipe.

In soils with percolation rates greater than 2-60 min/in the minimum vertical separation distance to the EHGW is 4' measured from the required 6" of system sand at the bottom of the Enviro-Septic<sup>®</sup> pipe.

Minimum naturally occurring pervious soil depth

In soils with percolation rates to 60 min/in, the minimum depth of naturally occurring pervious material under a bed is 4', measured from the required 6" of system sand at the bottom of the Enviro-Septic<sup>®</sup> pipe.

---

**Remedial use  
provisions**

Minimum vertical separation distances to EHGW

For remedial systems in soils with percolation rates of 2 min/in or less, the minimum vertical separation distance to the EHGW, measured from the bottom of the 6" of system sand below the Enviro-Septic<sup>®</sup> pipe, may be reduced to 3' if allowed by the local approving authority.

In soils with percolation rates greater than 2 to 90 min/in, the minimum vertical separation distance to the EHGW, measured from the bottom of the 6" of system sand below the Enviro-Septic<sup>®</sup> pipe, may be reduced to 2' if allowed by the local approving authority.

Minimum naturally occurring pervious soil depth

In soils with percolation rates to 90 min/in the depth of naturally occurring pervious material under a bed, measured from the bottom of the 6" of system sand below the Enviro-Septic<sup>®</sup> pipe, may be reduced to no less than 2' if allowed by the local approving authority.

---

## Section E

### Installation, Handling, and Storage Guidelines

---

**Introduction** These guidelines must be observed while installing, handling, and storing Enviro-Septic® products.

---

**Site preparation** Here are some site preparation guidelines.

- Remove stumps and organic matter under the required sand bed area of a proposed system, including the slope extensions of raised systems.

Note: In soils with percolation rates of up to 60 minutes per inch also remove the A Horizon (topsoil).

- Maintain the existing characteristics of the underlying soil as much as possible.
- Add the system sand and/or surrounding sand on the same day that the leach area is excavated.
- Do not allow water to run into or over the system during construction.
- Do not work wet or frozen soils.
- Do not smear or compact soils while preparing the site.

Reference: See “smear,” p. 8.

Note: Excavation irregularities shall be filled with system sand or Title 5 fill.

---

**Soil moisture construction limitation** If a fragment of soil from about 9” below the surface can easily be rolled into a wire, the soil moisture content is too high for construction.

---

**Soil compaction** Minimize machine movement to avoid soil compaction and destruction of the soil structure under and around the system. Be careful not to compact soil on the down slope side of the system.

---

**Level line tolerances** Use a laser level or transit to install lines level. Variations beyond ¼” may affect system performance. Variations beyond 1” are not acceptable.

---

**Backfilling lines** Spread system sand between the lines; carefully walk between the lines to insure system sand fills all void spaces beneath the Enviro-Septic® pipe. Finish spreading system sand to the top of the lines.

---

**Backfilling and final grading** Spread a minimum of 6” of system sand over the pipe. Spread the remaining surrounding sand and a minimum of 4” of topsoil. Final grading should shed water away from the system.

Note: A tracked vehicle may be used to spread the system sand and topsoil as long as it maintains at least 12” of cover over the pipe.

---

*Continued*

# Installation, Handling, and Storage Guidelines, Continued

**Erosion control** Protect the site from erosion by proper grading, mulching, seeding, and control of runoff.

**Use raised connections** Raised connections consist of offset adapters, 4" PVC sewer and drain pipe, and 90° elbows. Use raised connections to connect lines of Enviro-Septic® pipe. They enable greater liquid storage capacity and increase the bacterial surfaces being developed. Here are some diagrams along with installation notes.

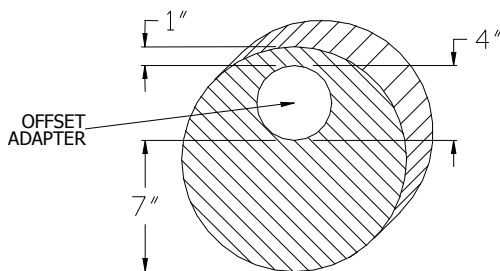

TOP VIEW

**Installation Notes:**

1. Insert PVC pipe no more than 4" into the offset adapter to prevent air locking.
2. Install the raised connection so that the top of the 90° bend is level with the top of the offset adapter.
3. Pack sand under and around the raised connection to prevent movement.

SIDE VIEW

END VIEW

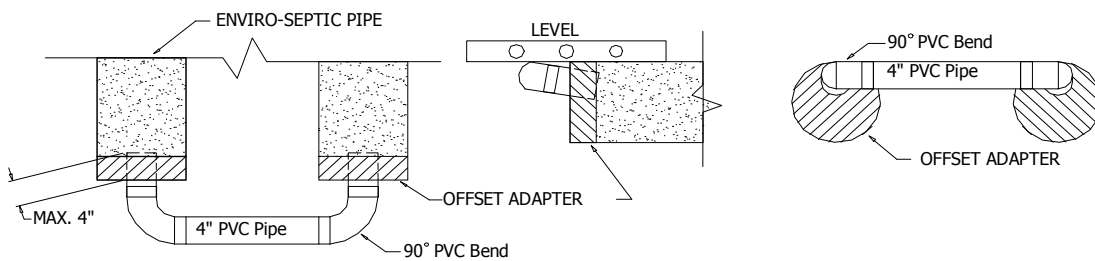

**Line spacers** Sand may be used to keep pipe in place while covering, but simple tools may also be constructed for this purpose. Here are two examples. One is made from rebar, the other from wood.

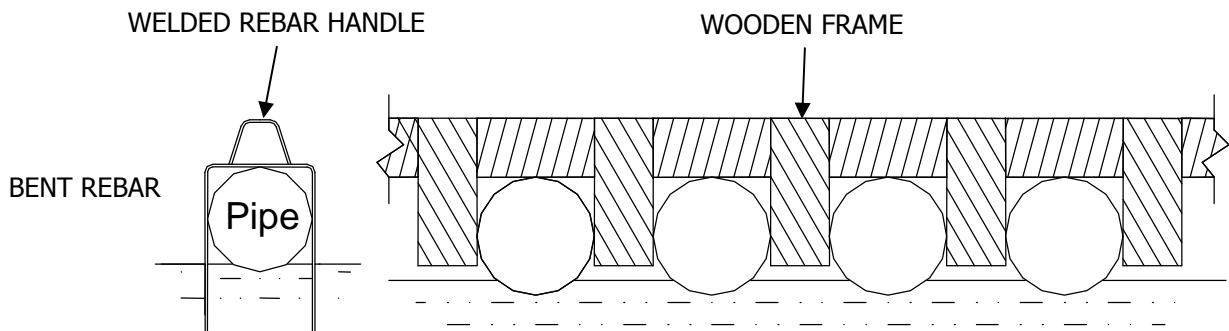

**Caution:** Remove all tools used as line spacers before final covering.

*Continued*

## Installation, Handling, and Storage Guidelines, Continued

---

### Storage

The outer fabric of the Enviro-Septic<sup>®</sup> pipe is ultra-violet stabilized. However, the protection breaks down after a period of time in direct sunlight. To prevent damage to the fabric, cover the pipe with an opaque tarp.

Store pipe on high and dry areas to prevent surface water and soil from entering the pipes or contaminating the fabric prior to installation.

Contamination Note: Keep mud, grease, oil, etc., from all system components.  
Avoid dragging pipe through wet or muddy areas.

---

## Section F

# System Sand Requirements

---

<b>Introduction</b>	This page describes the system sand requirements for the Enviro-Septic <sup>®</sup> wastewater treatment system.
<b>System sand</b>	<p><u>All configurations</u> of Enviro-Septic<sup>®</sup> require a minimum of 6" of system sand surrounding the circumference of the pipe.</p> <p><u>Percentage Restrictions</u> 35% <b>or less</b> of the total sand may be gravel. 40%-90% of the total sand is to be coarse and very coarse sand.</p> <p><u>Gravel Quality Restrictions</u> No gravel is to exceed ¾" in diameter. No gravel is smaller than 2mm/.0787" in diameter. (It must <b>not</b> pass through a #10 sieve.)</p> <p><u>Coarse Sand Quality Restrictions</u> No coarse sand is smaller than 0.5mm/.0196" in diameter. (It must <b>not</b> pass through a #35 sieve.)</p> <p><u>Fines Quality Restrictions</u> No more than 2% of the total sand may pass through a #200 sieve.</p> <p><u>ASTM Standard:</u> C-33 (concrete sand) meets the above requirements.</p>
<b>Surrounding sand</b>	Surrounding sand should be either system sand or Title 5 fill, 310 CMR 15.255 (3). Only surrounding sand may be placed under raised systems or where top soil and soil horizons with organic matter have been removed.
<b>Raised systems extensions</b>	<p>Raised systems require extensions.</p> <p><u>References:</u> See "Raised (Mounds) systems minimum fill extensions," p. 12 and 310 CMR 15.255.</p>
<b>Perimeter sand bed requirements</b>	<p>Sand beds sloping 10% or less require the system sand area to extend a minimum of 1 foot around the perimeter of the Enviro-Septic<sup>®</sup> pipe.</p> <p>Sand beds sloping greater than 10% require the system sand area to extend a minimum of 1 foot around the perimeter of the Enviro-Septic<sup>®</sup> pipe, and an additional 6" of system sand, measured from the bottom of the Enviro-Septic<sup>®</sup> pipe, must extend 3' on the downslope side.</p> <p><u>References:</u> See "Inground System Sections" diagrams, p. 28 and "Raised (Mounds) System Sections" diagrams, pp. 29-30.</p>

---

## Section G

### Standard System Configurations

#### Preview

---

#### Introduction

This section presents the standard system configurations in which Enviro-Septic<sup>®</sup> systems may be installed.

---

#### Low flow systems

Low flow systems in soils with perc rates up to 60 min/inch may use any of the configurations described in this section. Percolations rates of 61-90 min/inch require basic serial or multiple basic serial bed designs.

Reference: See “Low flow,” p. 7.

---

#### High flow systems

High flow systems in soils with perc rates up to 60 min/inch must be designed as combination or distribution box systems or as multiple bed systems. Percolations rates of 61-90 min/inch require basic serial or multiple basic serial bed designs.

Reference: See “High flow,” p. 7.

---

#### Line configurations

Enviro-Septic<sup>®</sup> systems may be designed in three line configurations.

1. Basic serial
  2. Combination
  3. Distribution box
- 

#### Elevation and slope configurations

These line configurations may be designed as inground or raised (mounds) systems on level or sloping terrain.

---

#### Sloping systems

The percentage of slope refers to the slope of the Enviro-Septic<sup>®</sup> system, not the existing terrain. The maximum sand bed slope for all systems is 25%. The maximum site slope is 3:1 (33%). A sloping system can be designed with more than one distinct slope and/or center-to-center pipe spacing in the same system.

---

#### Line orientation

Enviro-Septic<sup>®</sup> lines must be laid level and should run parallel to contours (perpendicular to sloping terrain).

---

#### Velocity reduction

If the slope of piping from the septic tank to the Enviro-Septic<sup>®</sup> is 10% or more up to a length of 50', or 5% or more for lengths over 50', a velocity reducer is necessary in the D-Box. A baffle or an inlet tee may be an adequate velocity reducer.

---

*Continued*

## Preview, Continued

---

**Pump system definition** A pump system uses a pump to elevate effluent to a D-Box which is required for velocity reduction in a basic serial system and also equally distributes effluent in combination, distribution box, or multiple bed systems.

---

**In this section** This section contains the following subjects.

<b>Subject</b>	<b>Page</b>
Basic Serial Systems	22
Combination Systems	23
Distribution Box Systems	25
Multiple Bed Systems	26
Inground System Sections	28
Raised (Mounds) System Sections	29

---

# Basic Serial Systems

---

**Introduction** Basic serial distribution is preferred for single beds of 500 GPD or less and multiple bed systems where each bed receives 500 GPD or less. Basic serial distribution is quick to develop a strong biomat in the first line, providing improved effluent treatment. Basic serial distribution provides a longer flow route to allow decomposition of solids and greases, providing improved long term treatment.

---

**Definition** A basic serial system is a single bed with a series of Enviro-Septic<sup>®</sup> lines connected at the ends with raised connections, using offset adapters and PVC pipe. One offset adapter is installed at the single inlet, and one offset adapter installed at the end of the system is connected to a single vent.

---

**Line length** Each line of a basic serial system has a maximum length of 100’.

---

**Basic serial system diagram** Here’s a plan view of an Enviro-Septic<sup>®</sup> basic serial system.  
Note: All systems require an inspection port (not shown). See Section K.

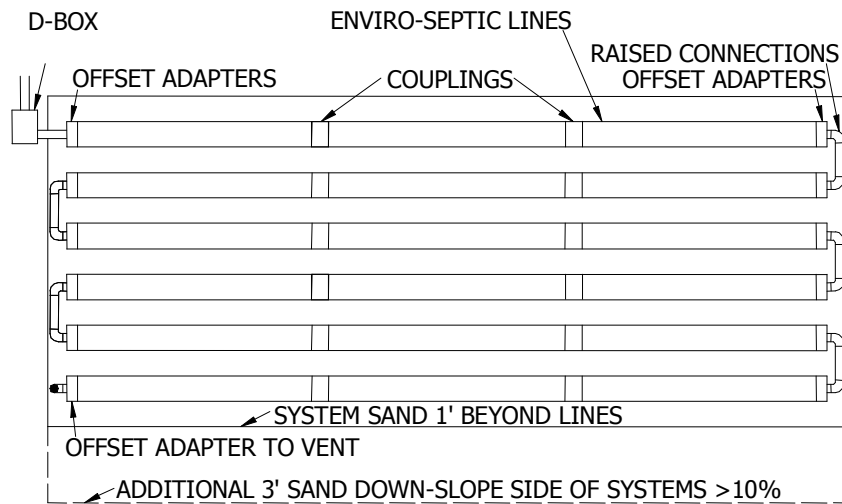

## Combination Systems

---

**Introduction** Combination distribution is required for systems with greater than 500 GPD and for multiple bed systems where each section receives no greater than 500 GPD. Combination distribution is quick to develop a strong biomat in the first line of each section providing improved effluent treatment. All systems require a distribution box for use as an observation port. Combination systems also use the same distribution box for dividing flow to multiple serial sections to provide longer flow routes to allow decomposition of solids and greases, providing improved long term treatment.

---

**Definition** A combination system is a bed of two or more sections of Enviro-Septic<sup>®</sup> lines in serial configuration supplied equally through a distribution box. Each section of a combination system is a series of Enviro-Septic<sup>®</sup> lines connected at the ends with raised connections, using offset adapters and PVC sewer and drain pipe. An offset adapter is installed at each section inlet, and at the end of each section where it is connected to a vent or vent manifold.

---

**Loading** Each section of a combination system has a maximum design flow of 500 GPD.

---

**Flow equalizers required** All distribution boxes that divide effluent flow in pump or gravity systems require flow equalizers in their outlets. Most flow equalizers are limited to a maximum of 10 gallons/minute in gravity systems and 20 gallons/minute in pumped systems.

Note: To prevent movement, be sure distribution boxes are placed on a stable soil base or concrete pad.

---

**Line length** Each line of a combination system has a maximum length of 100'.

---

**Section length requirement** Each section of a combination system must have at least the same minimum linear feet of pipe. The minimum linear feet of pipe per section is determined by dividing the total linear feet required by the number of sections. A section may exceed the minimum linear length. Lines within a section may vary in length to accommodate site constraints.

---

*Continued*

## Combination Systems, Continued

### Combination system diagram

Here's a plan view of an Enviro-Septic<sup>®</sup> combination system.  
Note: Inspection Port required (not shown). Refer to Section K.

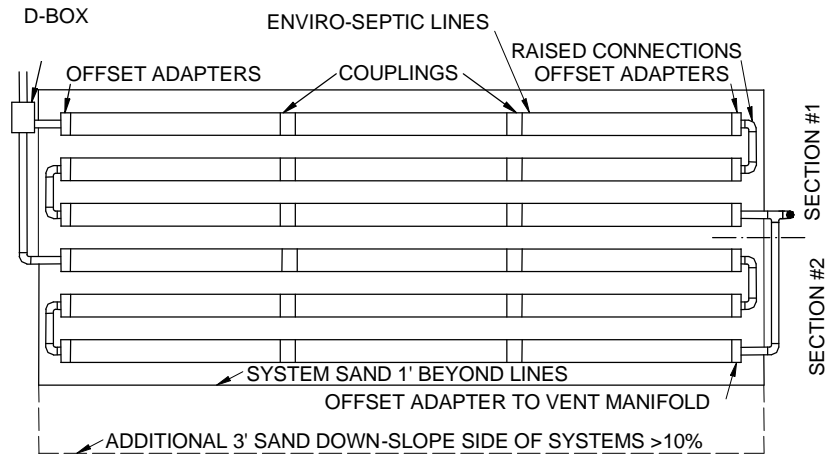

# Distribution Box Systems

---

**Introduction** Distribution box systems are the least preferred configuration and should only be used where site constraints do not allow the use of basic serial or combination systems. Distribution box systems disperse effluent in small amounts into several lines and take a longer time to reach maximum environmental efficiency.

---

**Definition** A distribution box system is a bed with each Enviro-Septic<sup>®</sup> line supplied equally through a distribution box. Each Enviro-Septic<sup>®</sup> line of a distribution box system has one offset adapter at each line inlet and one offset adapter at the end of each line connected to a vent or vent manifold.

---

**Flow equalizers required** All distribution boxes that divide effluent flow in pump or gravity systems require flow equalizers in their outlets. Most flow equalizers are limited to a maximum of 10 gallons/minute in gravity systems and 20 gallons/minute in pumped systems.

Note: To prevent movement, be sure distribution boxes are placed on a stable soil base or concrete pad.

---

**Line length requirement** Each line of a distribution box system has a maximum length of 100'. Each line of a distribution box system must have the same minimum linear feet of pipe. The minimum linear feet of each line is determined by dividing the total linear feet required by the number of lines.

---

**Distribution box system diagram** Here's a plan view of an Enviro-Septic<sup>®</sup> distribution box system. Note: Inspection Port required (not shown). Refer to Section K.

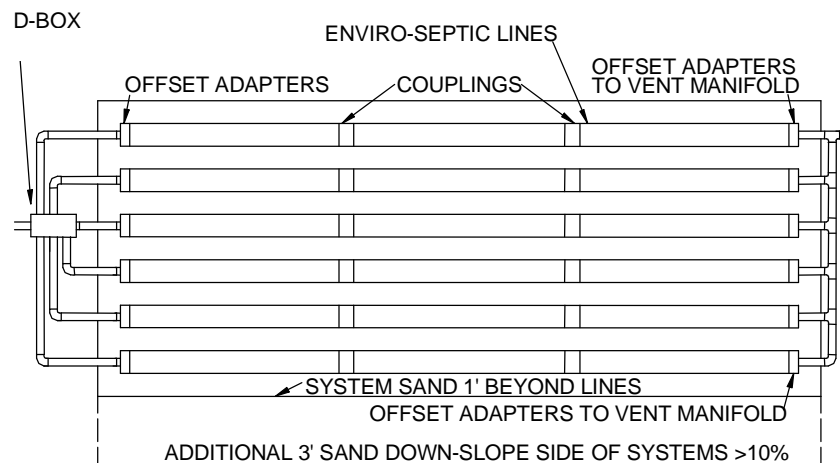

## Multiple Bed Systems

---

**Introduction** A multiple bed system may be used to accommodate site configuration constraints in soils with percolation rates up to 60 min/inch and is required for systems in soils with percolation rates of 61-90 min/inch when the total bed length required is greater than 102’.

---

**Definition** Multiple bed systems incorporate two or more beds, each bed with basic serial, combination serial, or distribution box configuration receiving effluent from a distribution box.

---

**Flow equalizers required** All distribution boxes used to divide effluent flow require flow equalizers in their outlets. Flow equalizers are limited to a maximum of 10 gallons/minute in gravity systems and 20 gallons/minute in flood dosed systems.

Note: To prevent movement, be sure distribution boxes are placed on undisturbed soil, sand or pea gravel base, or concrete pad.

---

**Loading** Each basic serial bed, section of a combination system, or line of a distribution box system has a maximum flow of 500 GPD.

---

**Bed length requirement** Each bed must have the same minimum linear feet of pipe. The minimum linear feet of pipe per bed is determined by dividing the total linear feet required in the Enviro-Septic<sup>®</sup> system by the number of beds. A bed may exceed the minimum linear length. Lines within a bed may vary in length to accommodate site constraints only in soils with percolation rate up to 60 min/inch.

Reference: See “Ten foot increments work best,” p. 12.

---

**Separation distances** For remedial systems, multiple beds in soils with percolation rates of 1-90 minutes per inch must be separated by a minimum of six feet of undisturbed natural soil.

For general use systems, multiple beds in soils with percolation rates of 1-60 minutes per inch must be separated by a minimum of ten feet of undisturbed natural soil.

---

**Multiple bed orientation** Multiple beds should be oriented along the contour of the site.

Note: All Enviro-Septic<sup>®</sup> systems are recommended to be designed and installed as long and narrow as possible for the site.

Reference: See “Longer lines preferable,” p. 10.

---

*Continued*

# Multiple Bed Systems, Continued

## Diagrams

These multiple bed plan views show a minimum horizontal separation distance of ten feet, as required in general use systems. If used in remedial use systems, the minimum horizontal separation distance is reduced to six feet. Note: Inspection Ports required (not shown). Refer to Section K.

### Basic Serial

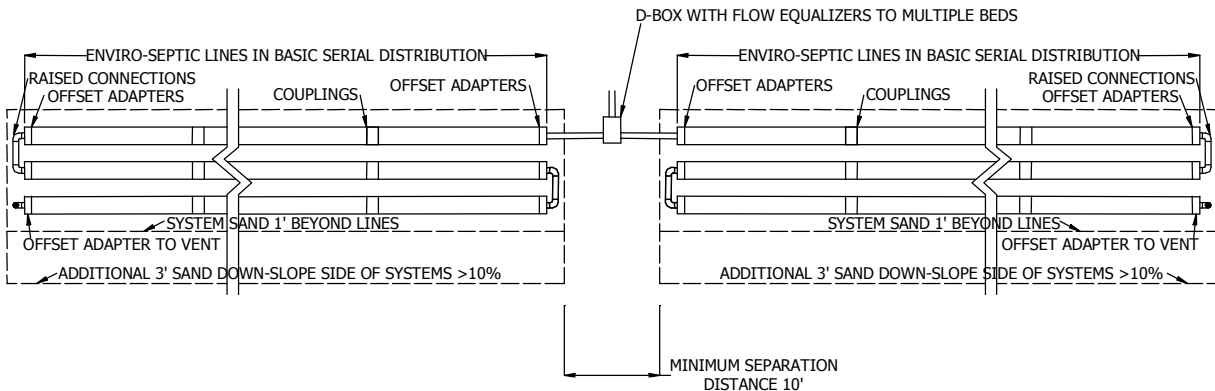

### Combination Serial

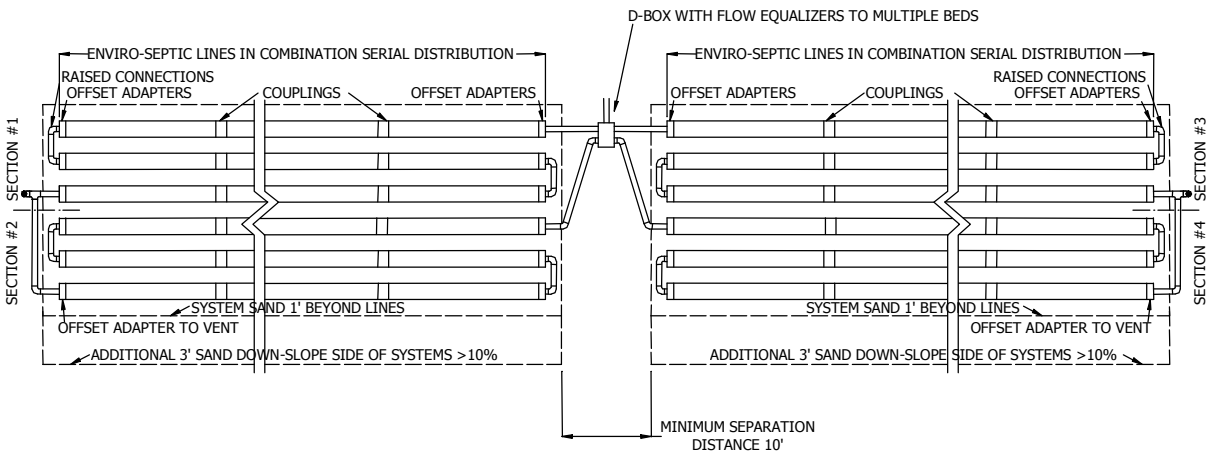

### Distribution Box

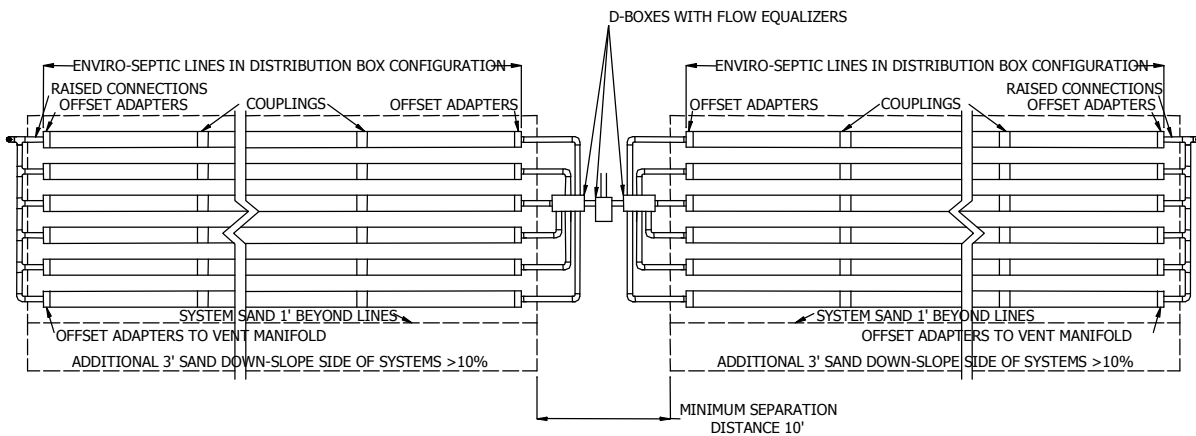

# Inground System Sections

**Introduction** Inground Enviro-Septic® systems are the preferred configuration for sites with no soil constraints to limit placement.

**Definition** Inground systems are configurations where the bottom of the system sand bed is below the existing grade. Note: Inspection Ports required (not shown). Refer to Section K.

## Inground level section

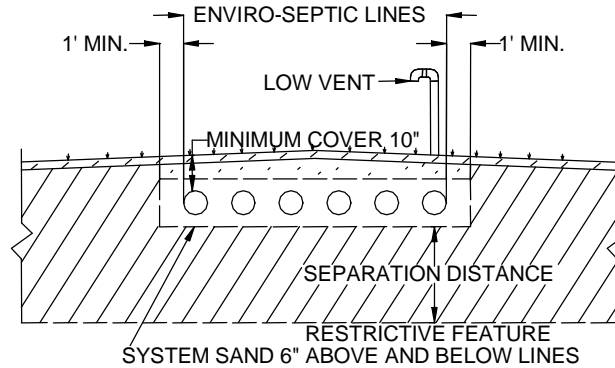

## Inground sloping to 10%

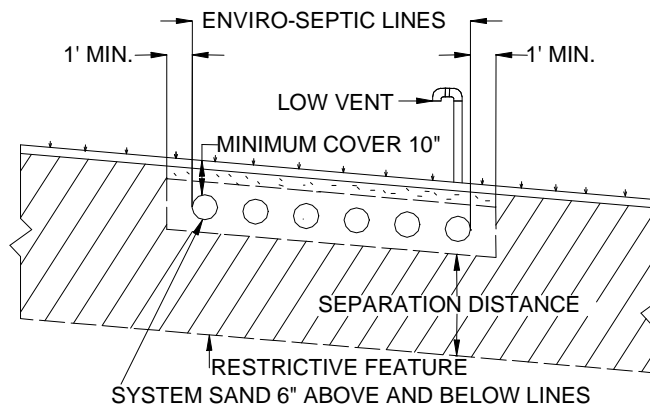

## Inground sloping >10%

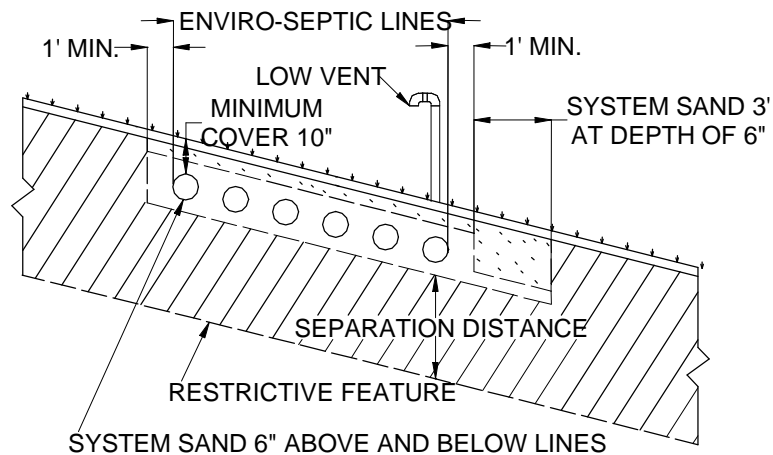

# Raised (Mounds) System Sections

## Introduction

All mounded systems shall be designed and constructed in accordance with 310 CMR 15.255. Raised Enviro-Septic® systems are designed for sites with soil or depth constraints that do not allow inground configurations.

## Definition

Raised systems are configurations where the bottom of the system sand bed is at or above the existing ground. Breakout elevation is the bottom of the System Sand bed/soil interface. **Schematics on this page revised September, 2009.** Note: Inspection Ports required (not shown). Refer to Section K.

### Raised level section

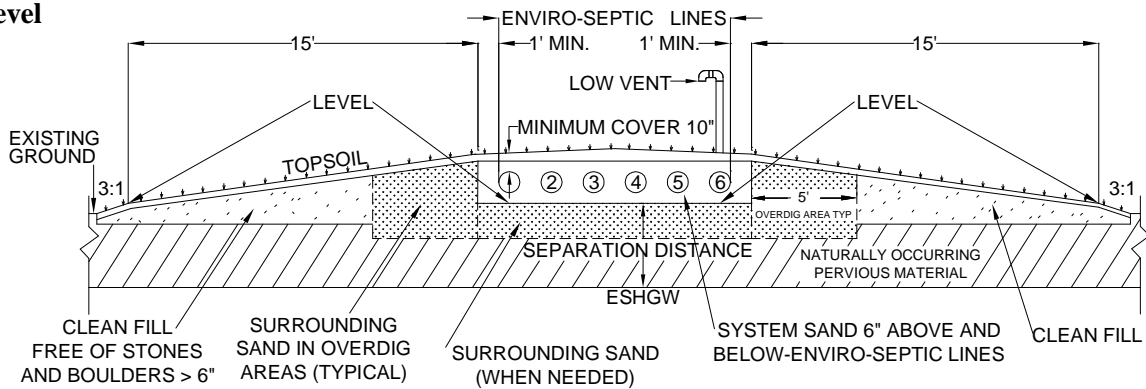

### Raised sloping to 10%

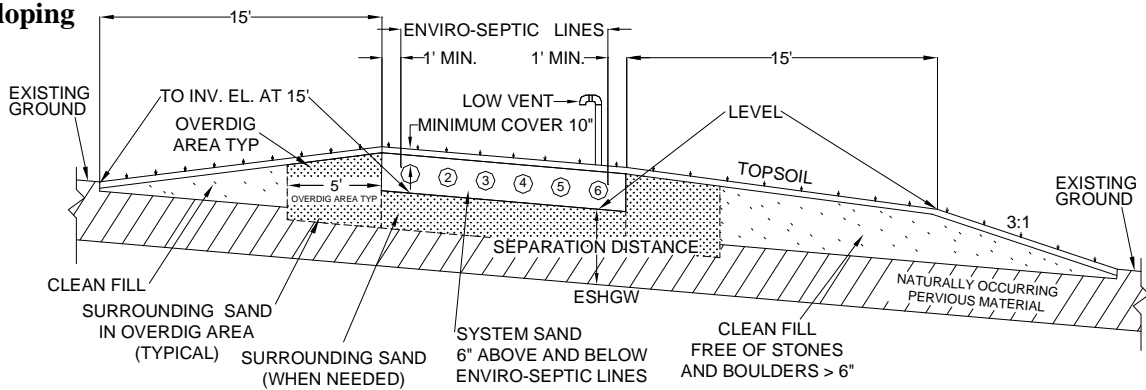

### Raised sloping >10%

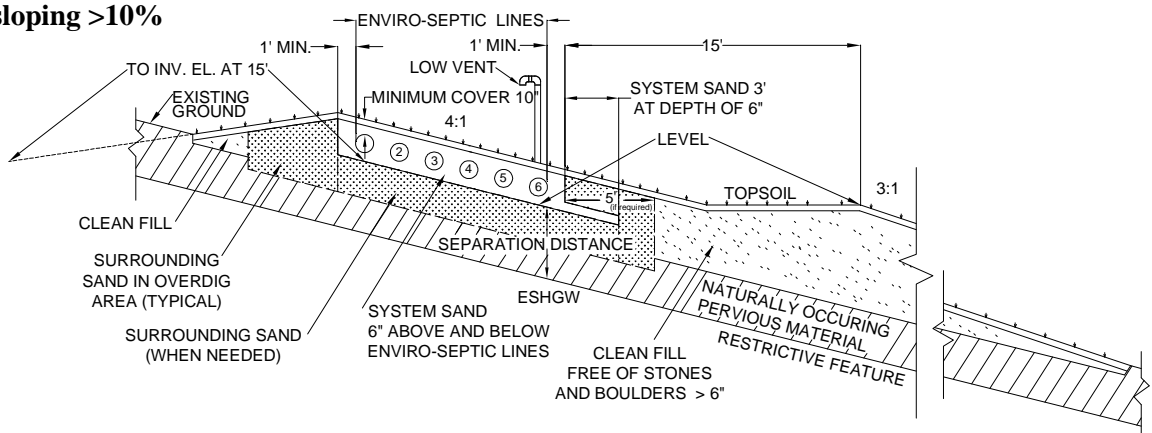



# Section H

## Non-Standard System Configurations

**Introduction** Non-standard configurations may accommodate system lengths longer than 100' and pipe lines shorter than 30'.

**Restriction** No onsite system may be located on concave slopes that concentrate surface flows.

**Total linear feet requirement** Each line of a distribution box system and each section of a combination system must have the same minimum linear feet of pipe. A section or line may exceed the minimum linear length. Lines within a section may vary in length to accommodate site constraints.

**Non-standard designation** Non-standard system configurations are not allowed for soils with percolation rates of 61-90 min/inch.

**Examples** Here are some examples using offset adapters and distribution boxes.  
 Note: Inspection Port required (not shown). Refer to Section K.

Offset adapters with raised straight connections allow systems to exceed 100' in length

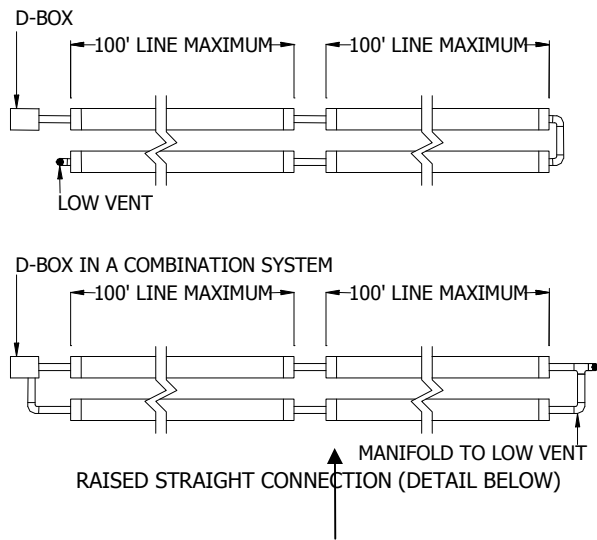

TOP VIEW

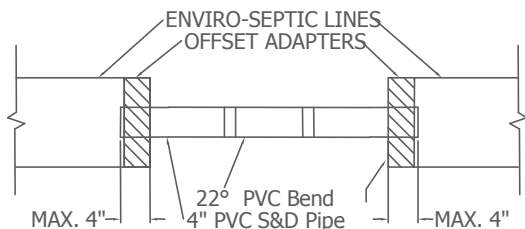

Combination configuration with pipe lengths less than 30'

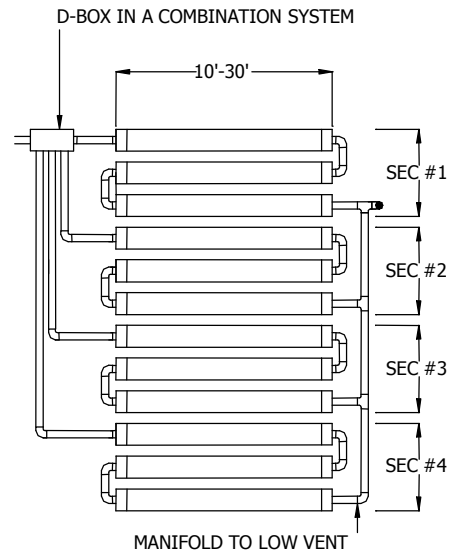

SIDE VIEW

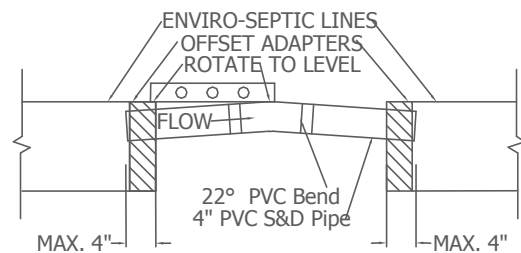

## Non-Standard System Configurations, Continued

---

### Curves

Curved configurations work well around objects, setbacks, and slopes.

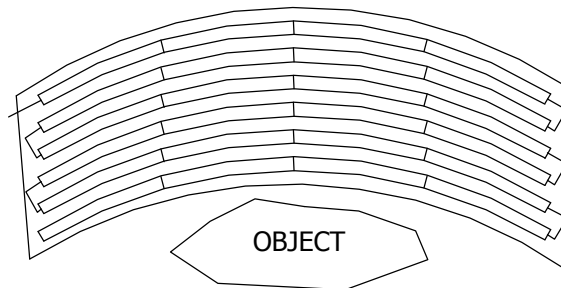

Note: Multiple curves can also be used.

---

### Angles

Angled configurations generally have one or more specific bends. Lines are angled by bending pipes or through the use of raised connections.

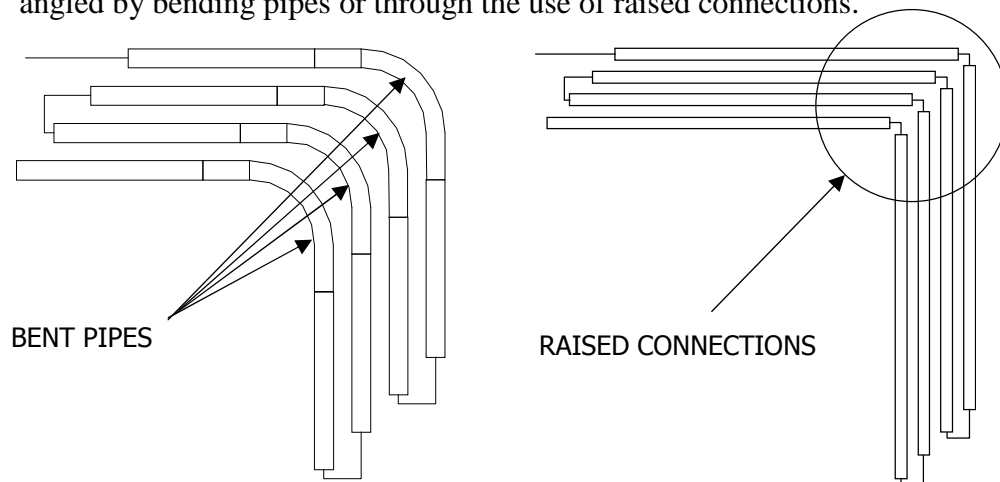

Note: A 10' length of pipe may take a 90° bend.

---

### Trapezoids

This combination system shows a trapezoidal configuration. A secondary purpose of this drawing is to illustrate two sections meeting minimum lengths.

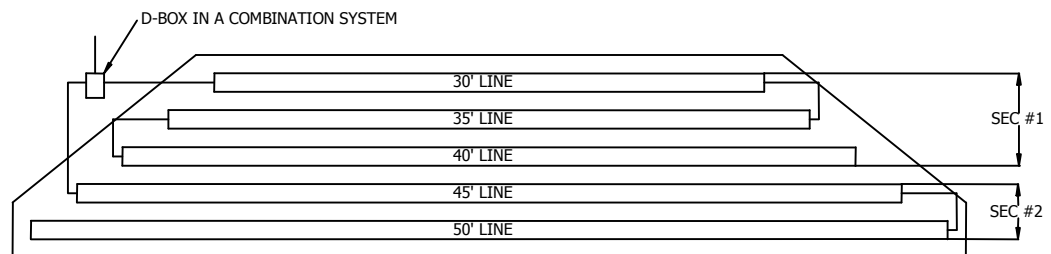

Example: Assume 180 linear feet of pipe is required within a trapezoidal area. Each section requires a minimum of 90 linear feet of pipe. Section #1 consists of 30', 35', and 40' lines for a total of 105'. Section #2 consists of 45' and 50' lines for a total of 95'. Each section contains at least the minimum 90' of pipe.

---

# Section I

## Pump System Requirements

---

<b>Introduction</b>	Pump systems typically supply effluent to Enviro-Septic <sup>®</sup> pipe using a pressured line and a distribution box as a velocity reducer when site conditions do not permit a gravity system. Pumps and chambers shall be designed in accordance with 310 CMR 15.231.
<b>Differential venting</b>	All pump systems must use differential venting. <u>Reference:</u> See Section J, “Venting Requirements,” p. 34.
<b>Velocity control</b>	It is important to control the rate at which effluent enters Enviro-Septic <sup>®</sup> pipe. Excessive effluent velocity can disrupt suspended solids that have settled out in the Enviro-Septic <sup>®</sup> pipes.
<b>Velocity reduction</b>	Never pump effluent directly into Enviro-Septic <sup>®</sup> pipes. Pressurized lines must discharge into a velocity reducing distribution box with a baffle, a 90-degree elbow, or a tee fitting. If the design already incorporates a distribution box to divide effluent flow, an additional distribution box may not be necessary.
<b>Pipe length per pumped gallon</b>	Each gallon of effluent pumped per cycle requires a minimum of 1.0’ of Enviro-Septic <sup>®</sup> pipe.
<b>Basic System GPM Limit</b>	A maximum of 40 GPM is permitted for each basic serial bed.
<b>GPM per flow equalizer limit</b>	A flow equalizer used in a pump system is limited to a maximum of 20 gallons per minute.
<b>Section or line GPM limit</b>	Each line of a pumped D-Box system or each section of a pumped combination system is limited to a maximum of 20 GPM. Each basic serial bed without a flow equalizer can have a maximum flow of 40 GPM.
<b>Pump cycling</b>	Pump cycling is recommended to be six or more cycles per day.

---

## Section J Venting Requirements

---

### General rule

Low and high vents are required of all systems to ensure that air is drawn completely through the entire Enviro-Septic<sup>®</sup> system. No additional vents may be located between the high vent and low vent. The opening of the high vent must be at least 10 feet above the opening of the low vent. High vents must provide at least the same flow capacity as low vents. Connections within the system must also have similar flow capacities.

Purpose: Venting design, installation, and maintenance must ensure that every linear foot of Enviro-Septic<sup>®</sup> pipe in all serial beds, sections, or lines receives oxygen to accommodate natural biologic activity.

---

### Low vent locations

Low vents are installed through an offset adapter at the end of each

- serial system or bed
  - section of a combination system
  - line of a distribution box system.
- 

### High vent locations

High vents are installed in a variety of locations based on the system design.

- **The roof vent will function as the high vent** if there are no pumps, restrictions, or other vents between the low vent and the roof vent.
  - If a restriction is placed between the low vent and the roof vent, a high vent is required through an unused distribution box outlet.
  - In pumped systems a high vent is required through an unused distribution box outlet.
- 

### High vent on D-Box

This diagram shows a high vent installed in a D-Box. This configuration is required in pumped systems or when other restrictions or vents are installed between the low vent and the roof vent.

#### DIFFERENTIAL VENTING

(TYPICAL - NOT TO SCALE)

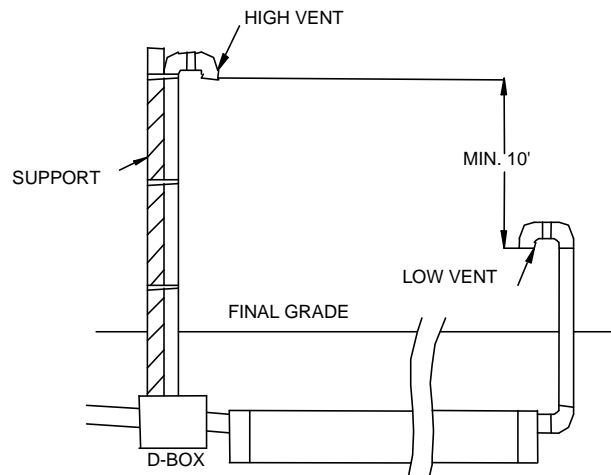

*Continued*

## Venting Requirements, Continued

**Vent manifolds** A vent manifold can be incorporated to connect the ends of a number of sections or lines of Enviro-Septic<sup>®</sup> pipe to a single vent opening. One 4" vent is required for every 1,000' of pipe. A 6" manifold and vent stack may vent up to 3,000' of pipe.

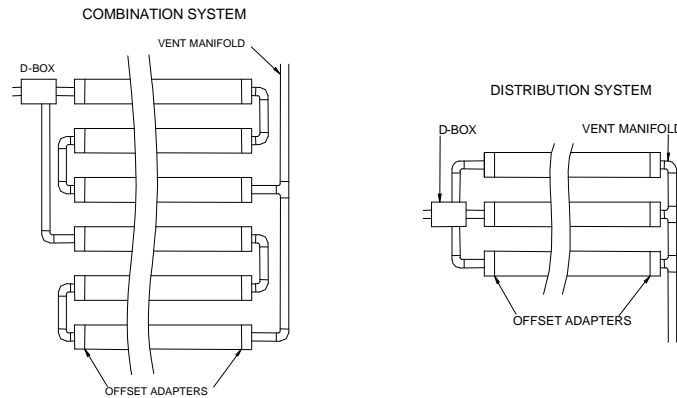

### Remote vent piping slope

Remote vent piping should slope downward toward the system to prevent moisture from collecting in the piping and blocking air passage. If site conditions do not allow the pipe to the vent to slope back toward the system, the low point of the connecting pipe should be drilled to allow drainage provided that the connecting pipe invert is above the highest point of the D-Box and all of the Enviro-Septic<sup>®</sup> lines.

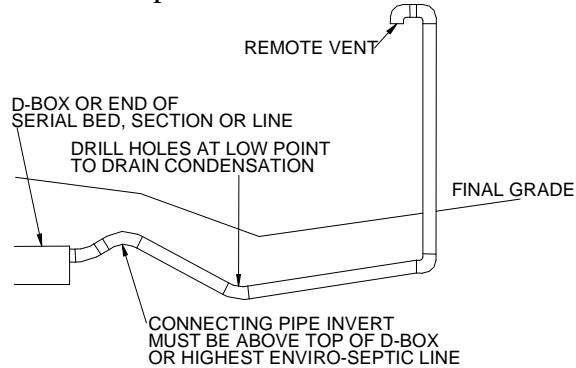

## Section K Inspection Port Requirements

---

**Massachusetts  
requires  
inspection ports**

All soil absorption systems shall have a minimum of one inspection port consisting of a perforated four inch pipe placed vertically down to the naturally occurring soil or sand fill below the System Sand. The pipe shall be capped with a screw type cap and accessible to within three inches of final grade. See Title 5, 310 CMR 15.240 (13.)

---

**Distribution Box  
not to be used  
for inspection  
port**

An observation port through the distribution box does **not** qualify as an inspection port in the bed.

---

**Inspection Port  
Installation**

The bottom of the inspection port is located 6" below the bottom of the Enviro-Septic pipe. The proper placement and installation of the required inspection port is shown in the diagram below.

**4"Ø PERFORATED INSPECTION PORT TO BOTTOM OF  
SYSTEM SAND AND THREADED CAP WITHIN 3" OF FINAL  
GRADE. WRAP PIPE WITH PERMEABLE GEOTEXTILE  
FABRIC TO ELIMINATE SAND INFILTRATION.**

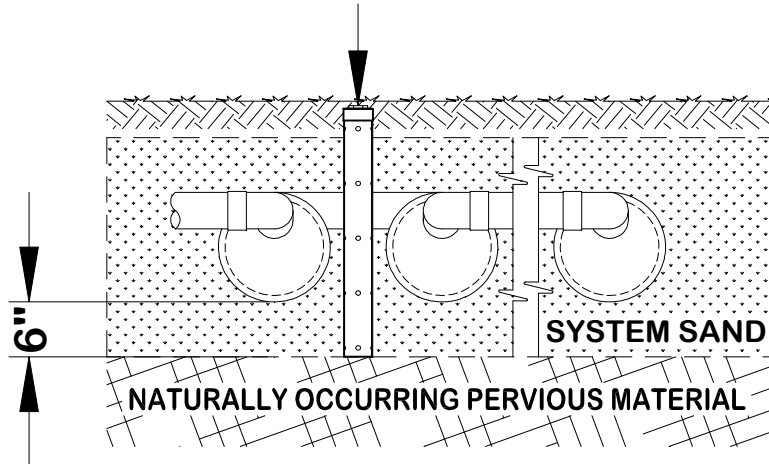

## Section L

### Bottom Drains and Requirements

---

**Purpose** Bottom drains aid in the rejuvenation of overloaded or abused systems and are recommended for commercial systems at risk of misuse, under pavement, or in inaccessible areas. Bottom drains allow effluent to be pumped from systems without requiring excavation. Once pumped, systems may be rejuvenated instead of replaced.

---

- Requirements** Bottom drains connect to sealed drain sumps. Here are some drain requirements.
- The top of the drain sump should be a minimum of 12” above the top of the highest Enviro-Septic® pipe.
  - The bottom drain inlet must be a minimum of 18” above the drain sump floor.
  - Level systems may use single drain sumps.
  - Sloping systems may require multiple drain sumps.
  - All bottom drain connections and drain sumps must be sealed.
  - Install only at the end of each basic serial bed, combination serial section, or each distribution system line.
- 

**Double offset adapter** Bottom drains require a double offset adapter at the end of each basic serial bed, combination serial section, or distribution system line.

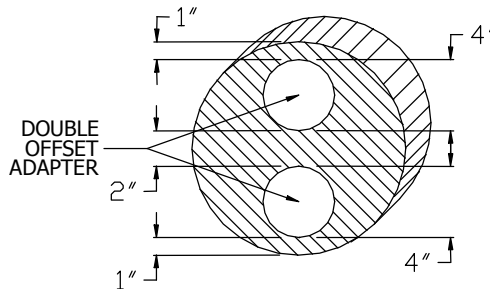

**End view** Here’s an end view of a system with a bottom drain and drain sump connecting each line on a distribution box system.

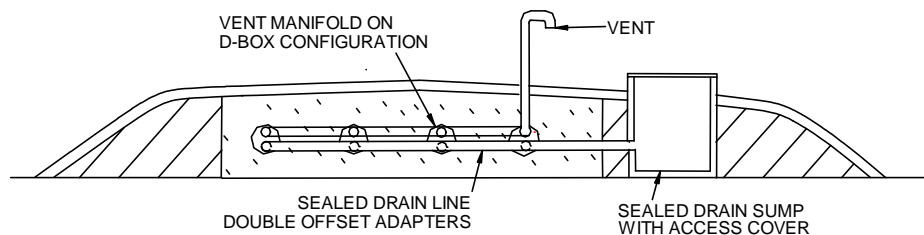

## Section M

### System Rejuvenation and Expansion

---

**Introduction** This section covers procedures for rejuvenating systems installed according to this manual, but failing because of misuse. It also explains how to expand existing systems.

---

**Why systems fail** System failures related to misuse or lack of oxygen, almost without exception, are related to the conversion of bacteria from an aerobic to an anaerobic state. Flooding, improper venting, alteration or lack of oxygen, sudden use changes, introduction of chemicals or medicines, and a variety of other conditions can contribute to this problem.

---

**Rejuvenating failing systems** Failing systems need to be returned from an anaerobic to an aerobic state. Most Enviro-Septic<sup>®</sup> systems can be put back on line and not require costly removal and replacement by using the following procedure.

1. Determine the problem causing system failure and repair.
  2. Drain the system by pumping out the sump of a bottom drain or by excavating one end of all the lines and removing the end cap or offset adapter.
  3. Drain the lines.
  4. If foreign matter has entered the system, flush the pipes.
  5. Safeguard the open excavation.
  6. Guarantee a passage of air through the system.
  7. Allow all lines to dry for a minimum of 72 hours.
  8. Manually excavate a small area of system sand adjacent to the pipe.  
Note: System sand in failed systems is blackened by anaerobic bacteria. Rejuvenation returns the sand to nearly its original color.
  9. When the system sand color has returned, re-assemble the system to its original design configuration.
- 

**System expansion** Enviro-Septic<sup>®</sup> systems are easily expanded by adding equal lengths of pipe to each line of the original design or by adding additional equal sections.

Note: All system expansions need to meet State and/or local regulations.

---

**Re-usable pipe** Enviro-Septic<sup>®</sup> components are not biodegradable and may be reused. In cases of improper installation it may be possible to excavate, clean, and reinstall all Enviro-Septic<sup>®</sup> system components.

---

**System replacement** If system components are damaged, remove and replace.

---

# Section N

## Quick Reference Guide for Percolation Rates Up to 60 Minutes/Inch

**Purpose** The unique Enviro-Septic<sup>®</sup> design provides an infinite number of system configurations that vary in length, width, slope, and shape. The purpose of this guide is to help designers compare layouts for any site quickly and easily. We recommend designers read this entire manual before using this Quick Reference Guide.

**Exceptions require variance** Exceptions to any requirements used in this quick reference guide require a variance from the local approving authority.

**Minimum separation distances** Title 5, 310 CMR 15.000 of the State Environmental Code establishes rules for minimum vertical and horizontal separation distances. Setback distances are measured from the outer edge of the required system sand. The distances to EHGW and other restrictive features are measured from the bottom of the 6” of system sand below the Enviro-Septic<sup>®</sup> pipe.

**System configuration** Basic serial configuration is recommended for low flow systems. High flow systems are preferably designed as combination systems or multiple serial bed systems, but distribution box systems may also be used.

**Procedure** Complete these tasks to size a single level Enviro-Septic<sup>®</sup> system.

**Task 1: Determine the linear feet of Enviro-Septic<sup>®</sup> pipe required.**

Use the percolation rate and the number of bedrooms or the commercial GPD in Table A below to determine the linear feet of Enviro-Septic<sup>®</sup> pipe required.

Table A: Linear Footage

Perc rate Min/Inch	Number of Bedrooms						Add'l Room	Commercial Per 100 GPD
	2	3	4	5	6			
<b>1-9</b>	100	150	200	250	300	50	50	
<b>10-13</b>	110	165	220	275	330	55	55	
<b>14-19</b>	120	<b>180</b>	240	300	360	60	60	
<b>20-30</b>	130	195	260	325	390	65	65	
<b>31-40</b>	140	210	280	350	420	70	70	
<b>41-50</b>	150	225	300	375	450	75	75	
<b>51-60</b>	160	240	320	400	480	80	80	

Example: A three-bedroom home with an 18 min/inch percolation rate requires 180 feet of pipe.

Note: Each bedroom has a design flow of 110 GPD.

*Continued*

# Quick Reference Guide for Percolation Rates Up to 60 Minutes/Inch, Continued

## Task 2: Determine the percentage of slope on the proposed system.

Note: The maximum slope for a system is 25%. However, the site slope may be greater if fill or excavation is used to keep the system slope within the maximum.

Do you know the percentage of slope on the proposed system?

If yes, go to Task 3.

If no, follow this procedure to determine the percentage of system slope.

Step	Action
1	Identify the highest elevation of the proposed system site.
2	Identify the lowest elevation of the proposed system site.
3	Subtract the lowest elevation from the highest elevation = elevation change.
4	Measure the horizontal distance between the two elevations = horizontal length.
5	Divide the elevation change by the horizontal length = percentage of site slope.
6	Choose a percentage of slope to be used for the system. <u>Note:</u> The system slope does not need to be the same as the site slope.
7	Go to Task 3.

## Task 3: Determine the minimum center-to-center pipe spacing.

Use the percolation rate and the percentage of system slope in Table B below to determine the required minimum center-to-center pipe spacing.

Table B: Pipe Spacing

Percentage of System Slope	Percolation Rate Min/Inch					
	1-10	11-20	21-30	31-40	41-50	51-60
0-10%	1.5'	1.5'	1.75'	2.0'	2.5'	3.0'
11-15%	1.5'	1.75'	2.0'	2.25'	2.75'	3.25'
16-20%	1.75'	2.0'	2.25'	2.5'	3.0'	3.5'
21-25%	2.0'	2.25'	2.5'	2.75'	3.25'	3.75'

Example: A slope of ten percent or less with an 18 min/inch percolation rate requires pipe spacing of 1.5'.

*Continued*

# Quick Reference Guide for Percolation Rates Up to 60 Minutes/Inch, Continued

## Task 4: Determine pipe line layout.

IF...	THEN use Table C below to...
system length is not a limiting factor (preferred)	<ul style="list-style-type: none"> <li>find the pipe "Line Length/Ft" in the left column</li> <li>follow that row across to a number equal to or greater than the required "Linear Feet of Enviro-Septic<sup>®</sup>"</li> <li>follow that column down through the "# of Lines" row and across left to the required "Ctr to Ctr Spacing."</li> </ul>
system length is a limiting factor	<ul style="list-style-type: none"> <li>find the "Ctr to Ctr Spacing" in the bottom left hand column and follow that row across to the desired layout width</li> <li>follow that column up through the "# of Lines" row and up to the required linear feet of Enviro-Septic<sup>®</sup></li> <li>follow that row left to determine the pipe line length.</li> </ul>

Note: Dark shading in table highlights figures used in the example.

Line Length/Ft	40	60	80	100	120	140	160	180	200	220	240	260	280	300
20	40	60	80	100	120	140	160	180	200	220	240	260	280	300
25	50	75	100	125	150	175	200	225	250	275	300	325	350	375
30	60	90	120	150	180	210	240	270	300	330	360	390	420	450
35	70	105	140	175	210	245	280	315	350	385	420	455	490	525
40	80	120	160	200	240	280	320	360	400	440	480	520	560	600
45	90	135	180	225	270	315	360	405	450	495	540	585	630	675
50	100	150	200	250	300	350	400	450	500	550	600	650	700	750
55	110	165	220	275	330	385	440	495	550	605	660	715	770	825
60	120	180	240	300	360	420	480	540	600	660	720	780	840	900
65	130	190	260	325	390	455	520	585	650	715	780	845	910	975
70	140	210	280	350	420	490	560	630	700	770	840	910	980	1050
75	150	225	300	375	450	525	600	675	750	825	900	975	1050	1125
80	160	240	320	400	480	560	640	720	800	880	960	1040	1120	1200
85	170	255	340	425	510	595	680	765	850	935	1020	1105	1190	1275
90	180	270	360	450	540	630	720	810	900	990	1080	1170	1260	1350
95	190	285	380	475	570	665	760	855	950	1045	1140	1235	1330	1425
100	200	300	400	500	600	700	800	900	1000	1100	1200	1300	1400	1500
# of Lines	2	3	4	5	6	7	8	9	10	11	12	13	14	15
Ctr to Ctr Spacing														
1.50	2.50	4.00	5.50	7.00	8.50	10.00	11.50	13.00	14.50	16.00	17.50	19.00	20.50	22.00
1.75	2.75	4.50	6.25	8.00	9.75	11.50	13.25	15.00	16.75	18.50	20.25	22.00	23.75	25.50
2.00	3.00	5.00	7.00	9.00	11.00	13.00	15.00	17.00	19.00	21.00	23.00	25.00	27.00	29.00
2.25	3.25	5.50	7.75	10.00	12.25	14.50	16.75	19.00	21.25	23.50	25.75	28.00	30.25	32.50
2.50	3.50	6.00	8.50	11.00	13.50	16.00	18.50	21.00	23.50	26.00	28.50	31.00	33.50	36.00
2.75	3.75	6.50	9.25	12.00	14.75	17.50	20.25	23.00	25.75	28.50	31.25	34.00	36.76	39.50
3.00	4.00	7.00	10.00	13.00	16.00	19.00	22.00	25.00	28.00	31.00	34.00	37.00	40.00	43.00
3.25	4.25	7.50	10.75	14.00	17.25	20.50	23.75	27.00	30.25	33.50	36.75	40.00	43.25	46.50
3.50	4.50	8.00	11.50	15.00	18.50	22.00	25.50	29.00	32.50	36.00	39.50	43.00	46.50	50.00
3.75	4.75	8.50	12.25	16.00	19.75	23.50	27.25	31.00	34.75	38.50	42.25	46.00	49.75	53.50
4.00	5.00	9.00	13.00	17.00	21.00	25.00	29.00	33.00	37.00	41.00	45.00	49.00	53.00	57.00
4.25	5.25	9.50	13.75	18.00	22.25	26.50	30.75	35.00	39.25	43.50	47.75	52.00	56.25	60.50
4.50	5.50	10.00	14.50	19.00	23.50	28.00	32.50	37.00	41.50	46.00	50.50	55.00	59.50	64.00
4.75	5.75	10.50	15.25	20.00	24.75	29.50	34.25	39.00	43.75	48.50	53.25	58.00	62.75	67.50
5.00	6.00	11.00	16.00	21.00	26.00	31.00	36.00	41.00	46.00	51.00	56.00	61.00	66.00	71.00
Layout Width/Ft.														

Continued

# Quick Reference Guide for Percolation Rates Up to 60 Minutes/Inch, Continued

## Task 5: Calculate the total system sand bed area.

Massachusetts requires that Enviro-Septic<sup>®</sup> systems be no less than 60% of the area of a pipe and aggregate system and no less than 400 square feet. Complete this task to determine area size.

Add two feet to the layout width and line length from Table C and multiply them together to obtain the sand bed area in sq.ft. For sloping systems greater than 10%, add 5 feet to the system width and two feet to the pipe length and multiply them together. (The 5 foot width accounts for the 4 foot sand bed extension required on slopes of 10% or more.)

If the area calculated above is less than the minimum sand bed area size required by Massachusetts in Table D, see “Increasing sand bed area footage”, next page.

**Table D – Minimum Sand bed Area Size (sq.ft.)**

PERC RATE Min/Inch	2 BEDROOM 220 GPD				3 BEDROOM 330 GPD				4 BEDROOM 440 GPD				5 BEDROOM 550 GPD			
	SOIL CLASS				SOIL CLASS				SOIL CLASS				SOIL CLASS			
	I	II	III	IV	I	II	III	IV	I	II	III	IV	I	II	III	IV
1-5	400	400			400	400			400	440			446	550		
6	400	400			400	400			400	440			471	550		
7	400	400			400	400			400	440			485	550		
8	400	400			400	400			400	440			500	550		
10		400				400				440				550		
15		400	400			400	535			471	714			589	892	
20		400	400			400	582			498	776			623	971	
25		400	400			495	600			660	800			825	1000	
30		400	455			600	683			800	910			1000	1138	
40			528				792				1056				1320	
50			660	660			990	990			1320	1320			1650	1650
60			880	880			1320	1320			1760	1760			2200	2200

PERC RATE Min/Inch	6 BEDROOM 660 GPD				ADD'L. BEDROOM 110 GPD				COMMERICAL PER 100 GPD			
	SOIL CLASS				SOIL CLASS				SOIL CLASS			
	I	II	III	IV	I	II	III	IV	I	II	III	IV
1-5	535	660			89	110			81	100		
6	566	660			94	110			86	100		
7	582	660			97	110			88	100		
8	600	660			100	110			91	100		
10		660				110				100		
15		707	1070			117	178			107	162	
20		747	1165			124	194			113	176	
25		990	1200			165	200			150	182	
30		1200	1366			200	227			182	207	
40			1584				264				240	
50			1980	1980			330	330			300	300
60			2640	2640			440	440			400	400

Continued

## Quick Reference Guide for Percolation Rates of Up to 60 Minutes/Inch, Continued

---

**Increasing sand bed area footage** Our 3-bedroom home requires 180 linear feet of pipe at 1.5' on center. Using Table C, with 30' lines the system width is 8.5' with a sand bed area of 32'x10.5' for a total of 336 square feet of sand bed. To meet the Massachusetts minimum bed area requirement of 400 square feet for soil class II from Table D, our sand bed area must be increased. Our sand bed area may be increased by adding width and/or length to the system.

Adding width: To meet the minimum sand bed area size required, the minimum pipe spacing may be increased. Add 2 feet to the pipe length and divide the minimum sand bed area size by that amount to obtain the minimum sand bed width. Subtract 2 feet from the minimum sand bed width and find the line spacing that provides at least that layout width in Table C. For slopes greater than 10%, subtract 5 feet from the minimum sand bed width before referring to Table C for line spacing.

Adding width example: To increase the sand bed area footage in our example by adding width, divide 400' by 32' to obtain a minimum sand bed width of 12.5'. Subtract 2' from that to obtain the minimum layout width of 10.5'. Table C indicates that a line spacing of 1.75' on center provides a layout width of only 9.75' for a 6-line system, therefore, a line spacing of 2.0' on center and a layout width of 11' is needed to provide a sand bed width of 13' to meet the required 12.5' minimum sand bed width. This now gives us a sand bed area of 416 square feet (13'x32') and a system configuration of 6-30' lines spaced 2' on center.

Adding length: Add 2 feet to the system width (5 feet for slopes over 10%) and divide the minimum sand bed area size by that amount to obtain the minimum sand bed length required. Subtract 2 feet from the minimum sand bed length to obtain the pipe line length.

Adding length example: To increase the sand bed area footage in our example by adding length, divide 400' by 10.5' to obtain a sand bed length of 39'. Subtract 2' from that to obtain a line length of 37'. 39'x10.5' equals 410 square feet of sand bed area. The system configuration would be 6-37' lines spaced 1.5' on center.

Note: This example uses 6-37' line lengths. Limiting pipe to 5' and 10' lengths makes systems simpler to construct. This system would be more easily installed as 6-40' lines, eliminating the need to cut the pipe.

---

# Section O

## Quick Reference Guide for Percolation Rates of 61-90 Minutes/Inch

**Introduction** Systems in high-density soils or soils with slow percolation rates are limited in configuration to adequately disperse and treat effluent and minimize groundwater mounding.

**Purpose** The purpose of this guide is to help designers choose system layouts for percolation rates in the 61-90 minutes/inch range.

We recommend designers read this entire manual before using this Quick Reference Guide.

**Restriction** Installations in soils with percolation rates of 61-90 minutes/inch are restricted to remedial use systems only.

**Exceptions require variance** Exceptions to any requirements used in this quick reference guide require a variance from the local approving authority.

**Minimum separation distances** Title 5, 310 CMR 15.000 of the State Environmental Code for Massachusetts establishes rules for minimum vertical and horizontal separation distances. Setback distances are measured from the outer edge of the required system sand. The distances to EHGW and other restrictive features are measured from the bottom of the 6" of system sand below the Enviro-Septic<sup>®</sup> pipe.

**Slope percentages allowed** Use Table E below to determine the maximum slope percentages allowed.

**Table E – Maximum Slopes for Perc. Rates 61-90 Min./Inch**

Perc. Rate	% Slope
61-70	15%
71-90	10%

**Additional site preparation requirement** For these dense soil systems, plow the system bed and sand extension area to a depth of 12" traveling parallel to the contour of the site. Place 12" of system sand (as measured from existing ground) on the bed area and 6" on sand extensions immediately to protect the site from damage by precipitation.

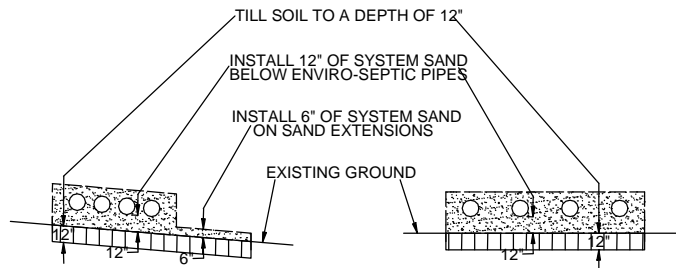

This additional requirement must be included on the system plan.

*Continued*

# Quick Reference Guide for Percolation Rates of 61-90 Minutes/Inch, Continued

**Procedure** Complete these tasks to design a single level Enviro-Septic<sup>®</sup> leaching system with percolation rates between 61-90 minutes/inch.

**Task 1: Determine the percentage of slope on the proposed system.**

Note: The maximum system slope is limited to 15% depending on percolation rates. However, the site slope may be greater if fill or excavation is used to keep the system slope within the maximum.

Do you know the percentage of slope on the proposed system?

If yes, go to Task 2.

If no, follow this procedure to determine the percentage of system slope.

Step	Action
1	Identify the highest elevation of the proposed system site.
2	Identify the lowest elevation of the proposed system site.
3	Subtract the lowest elevation from the highest elevation = elevation change.
4	Measure the horizontal distance between the two elevations = horizontal length.
5	Divide the elevation change by the horizontal length = percentage of site slope.
6	Choose a percentage of slope to be used for the system. <u>Note:</u> The system slope does not need to be the same as the site slope.
7	Go to Task 2.

**Task 2: Choose the proper sizing table.**

Sizing tables use the number of bedrooms for homes or the GPD flow in commercial installations to determine system size. System size is the total square footage of sand bed area required for a system. Sand bed area is designed as one or more individual sand beds. Sand bed widths are pre-established at 12', 9', and 6'. Sand bed lengths vary according to percolation rates and slope percentages.

Reference: See Level and Sloping Bed Diagrams, pp. 53-54.

When the system is for...	THEN use the following table to complete Task 3.
2-bedrooms	2-Bedroom Sizing, page 47
3-bedrooms	3-Bedroom Sizing, page 47
4-bedrooms	4-Bedroom Sizing, page 48
5-bedrooms	5-Bedroom Sizing, page 48
6-bedrooms	6-Bedroom Sizing, page 49
more than 6 bedrooms	Additional Bedroom Sizing, page 49
commercial use	Commercial System Sizing, page 50

*Continued*

# Quick Reference Guide for Percolation Rates of 61-90 Minutes/Inch, Continued

## Task 3: Determine bed(s) widths and lengths.

To determine the number and sizes of beds required, use the proper sizing table identified in task 2.

- Find your percolation rate and slope in the left hand column.  
Note: Percolation rates/slopes limit system widths to 12', 9', or 6'. No other system widths are allowed without approval by the local approval authority.
- Follow the row(s) across to the "Min. Bed Length" column and choose the longest bed length your site will accommodate.  
Note: Beds must be 32'-102' in length.
- If the minimum bed length exceeds 102 feet, divide the system into multiple beds of equal length.  
Example: A minimum bed length of 288' could be designed as 3 beds of 96' each.  
Note: This example supports using the longest beds possible. Four beds of 72', five beds of 58', etc., are other alternatives. Remember that 32' is the minimum bed length allowable.

## Task 4: Design beds.

- Design as many beds as required, inserting 4, 3, or 2 lines of Enviro-Septic<sup>®</sup> pipe in each as dictated by the bed width.  
Note: Pipe is designed 1 foot from the end of the sand bed.  
Example: A line of pipe in a 96' bed would be 94' long.  
Reference: See pipe lengths in Table F below
- Use the bed diagrams on pp. 53-54 to aid in the design of each bed.

### Pipe line and total footage lengths

Based on the bed width and length, this table lists pipe line lengths and total pipe footage in 5' increments.

**Table F – Pipe Line and Total Footage Lengths**

Bed Width	Number of pipe lines	Bed Length	32	37	42	47	52	57	62	67
		Pipe Length	30	35	40	45	50	55	60	65
6'	2	Total Pipe Ftg.	60	70	80	90	100	110	120	130
9'	3	Total Pipe Ftg.	90	105	120	135	150	165	180	195
12'	4	Total Pipe Ftg.	120	140	160	180	200	220	240	260

**Table F – Pipe Line and Total Footage Lengths**

Bed Width	Number of pipe lines	Bed Length	72	77	82	87	92	97	102
		Pipe Length	70	75	80	85	90	95	100
6'	2	Total Pipe Ftg.	140	150	160	170	180	190	200
9'	3	Total Pipe Ftg.	210	225	240	255	270	285	300
12'	4	Total Pipe Ftg.	280	300	320	340	360	380	400

*Continued*

# Quick Reference Guide for Percolation Rates of 61-90 Minutes/Inch, Continued

**Avoiding cutting Enviro-Septic<sup>®</sup> pipe** It is possible to keep pipe line lengths as multiples of 10' and avoid cutting a 10' pipe section.

Example: Let's say we have a 12' x 88' bed (4-lines of pipe) requiring a total pipe footage of 344'. Dividing 344' by 4 would suggest 4 lines of 86' each. Extending the bed 4 feet would allow 4 lines of 90 feet each and eliminate cutting a section of pipe.

## Task 5: Increase system size to meet Massachusetts' requirements.

Massachusetts requires that Enviro-Septic<sup>®</sup> systems be no less than 60% of the area of a pipe and aggregate system. Complete this task to determine the area size required by Massachusetts. Use Table G below to find the appropriate minimum sand bed area size required by the State of Massachusetts.

**Table G – Minimum Sand Bed Area Size (sq.ft.)**

Perc Rate Min/Inch	2-Bedroom	3-Bedroom	4-Bedroom	5-Bedroom	6-Bedroom	Add'l Bedroom	Commercial Per 100 GPD
61-90	880	1320	1760	2200	2640	440	400

Example: Let's say we have a 4-bedroom system in soil with a perc rate of 66 min/inch on a 4% slope. Our 4-bedroom sizing table requires a minimum bed length of 88' with 4 lines and a sand bed width of 12'.

To meet Massachusetts' requirements in Table G, our 4-bedroom house requires a minimum sand bed area size of 1760 sq. ft. The 88' x 12' bed would use 86' line lengths to provide a total of 1056 sq.ft. Instead of cutting the last pipe of each line to 6', the full 10' should be used to provide 4-90' lines. The 90' lines will provide a bed length of 92'. Divide the needed 1760 sq.ft. by the 92' bed to obtain a width of 20'. The 4-90' lines spaced 3' apart should be centered in the 20' by 92' bed.

Note 1: Sand bed extensions at the pipe ends are limited to 1 foot from the offset adapter for purposes of calculating the effective bed size.

Note 2: Sand bed extensions on systems sloping 5-15% are limited to 1 foot from the upslope side of the highest pipe for purposes of calculating bed size. Additional bed width must be made on the down slope side.

## Quick Reference Guide for Percolation Rates of 61-90 Minutes/Inch, Continued

---

**System  
configuration  
requirement**

Basic serial configuration is required for systems in soils with perc rates of 61-90 min/inch.

Systems with a design flow greater than 500 GPD must be divided into multiple beds. No bed in a multiple bed system can accept more than 500 GPD.

---

## Sizing Tables (percolation rates 61-90 min/inch)

### 2-Bedroom

Perc. Rate/Slope	Sand Bed Area(sq. ft.)	Sand Bed Width	Number of Lines	Ctr. to Ctr. Spacing	Min. Bed Length
61-70 / 0%-<5%	523	12'	4	3'	44'
61-70 / 0%-<5%	523	9'	3	3'	58'
61-70 / 0%-<5%	523	6'	2	3'	87'
61-70 / 5%-<10%	601	12'	4	1.5'	50'
61-70 / 5%-<10%	601	9'	3	1.5'	67'
61-70 / 5%-<10%	601	6'	2	1.5'	100'
61-70 / 10%-15%	628	12'	4	1.5'	53'
61-70 / 10%-15%	628	9'	3	1.5'	73'
71-80 / 0%-<5%	559	12'	4	3'	47'
71-80 / 0%-<5%	559	9'	3	3'	62'
71-80 / 0%-<5%	559	6'	2	3'	93'
71-80 / 5-10%	643	12'	4	1.5'	54'
71-80 / 5%-10%	643	9'	3	1.5'	71'
71-80 / 5%-10%	643	6'	2	1.5'	107'
81-90 / 0%-<5%	602	9'	3	3'	67'
81-90 / 0%-<5%	602	6'	2	3'	100'
81-90 / 5%-10%	692	9'	3	1.5'	77'
81-90 / 5%-10%	692	6'	2	1.5'	115'

### 3-Bedroom

Perc. Rate/Slope	Sand Bed Area (sq. ft.)	Sand Bed Width	Number of Lines	Ctr. to Ctr. Spacing	Min. Bed Length
61-70 / 0%-<5%	784	12'	4	3'	65'
61-70 / 0%-<5%	784	9'	3	3'	87'
61-70 / 0%-<5%	784	6'	2	3'	131'
61-70 / 5%-<10%	902	12'	4	1.5'	75'
61-70 / 5%-<10%	902	9'	3	1.5'	100'
61-70 / 5%-<10%	902	6'	2	1.5'	150'
61-70 / 10%-15%	941	12'	4	1.5'	78'
61-70 / 10%-15%	941	9'	3	1.5'	105'
71-80 / 0%-<5%	839	12'	4	3'	70'
71-80 / 0%-<5%	839	9'	3	3'	93'
71-80 / 0%-<5%	839	6'	2	3'	140'
71-80 / 5-10%	965	12'	4	1.5	80'
71-80 / 5%-10%	965	9'	3	1.5'	107'
71-80 / 5%-10%	965	6'	2	1.5'	161'
81-90 / 0%-<5%	902	9'	3	3'	100'
81-90 / 0%-<5%	902	6'	2	3'	150'
81-90 / 5%-10%	1038	9'	3	1.5'	115'
81-90 / 5%-10%	1038	6'	2	1.5'	173'

*Continued*

## Sizing Tables (percolation rates 61-90 min/inch), Continued

### 4-Bedroom

Perc. Rate/Slope	Sand Bed Area (sq. ft.)	Sand Bed Width	Number of Lines	Ctr. to Ctr. Spacing	Min. Bed Length
61-70 / 0%-<5%	1046	12'	4	3'	88'
61-70 / 0%-<5%	1046	9'	3	3	116'
61-70 / 0%-<5%	1046	6'	2	3'	174'
61-70 / 5%-<10%	1203	12'	4	1.5'	101'
61-70 / 5%-<10%	1203	9'	3	1.5'	134'
61-70 / 5%-<10%	1203	6	2	1.5'	201'
61-70 / 10%-15%	1255	12'	4	1.5'	105'
61-70 / 10%-15%	1255	9'	3	1.5'	139'
71-80 / 0%-<5%	1118	12'	4	3'	94'
71-80 / 0%-<5%	1118	9'	3	3'	124'
71-80 / 0%-<5%	1118	6'	2	3'	186'
71-80 / 5-10%	1286	12'	4	1.5'	108'
71-80 / 5%-10%	1286	9'	3	1.5'	143'
71-80 / 5%-10%	1286	6'	2	1.5'	214'
81-90 / 0%-<5%	1203	9'	3	3'	134'
81-90 / 0%-<5%	1203	6'	2	3'	201'
81-90 / 5%-10%	1383	9'	3	1.5'	154'
81-90 / 5%-10%	1383	6'	2	1.5'	231'

### 5-Bedroom

Perc. Rate/Slope	Sand Bed Area (sq. ft.)	Sand Bed Width	Number of Lines	Ctr. to Ctr. Spacing	Min. Bed Length
61-70 / 0%-<5%	1307	12'	4	3'	109'
61-70 / 0%-<5%	1307	9'	3	3'	145'
61-70 / 0%-<5%	1307	6'	2	3'	218'
61-70 / 5%-<10%	1503	12'	4	1.5'	126'
61-70 / 5%-<10%	1503	9'	3	1.5'	167'
61-70 / 5%-<10%	1503	6	2	1.5'	251'
61-70 / 10%-15%	1568	12'	4	1.5'	131'
61-70 / 10%-15%	1568	9'	3	1.5'	174'
71-80 / 0%-<5%	1398	12'	4	3'	117'
71-80 / 0%-<5%	1398	9'	3	3'	155'
71-80 / 0%-<5%	1398	6'	2	3'	233'
71-80 / 5-10%	1608	12'	4	1.5'	134'
71-80 / 5%-10%	1608	9'	3	1.5'	179'
71-80 / 5%-10%	1608	6'	2	1.5'	268'
81-90 / 0%-<5%	1504	9'	3	3'	168'
81-90 / 0%-<5%	1504	6'	2	3'	251'
81-90 / 5%-10%	1730	9'	3	1.5'	193'
81-90 / 5%-10%	1730	6'	2	1.5'	288'

Continued

## Sizing Tables (percolation rates 61-90 min/inch), Continued

### 6-Bedroom

Perc. Rate/Slope	Sand Bed Area (sq. ft.)	Sand Bed Width	Number of Lines	Ctr. to Ctr. Spacing	Min. Bed Length
61-70 / 0%-<5%	1569	12'	4	3'	131'
61-70 / 0%-<5%	1569	9'	3	3'	174'
61-70 / 0%-<5%	1569	6'	2	3'	262'
61-70 / 5%-<10%	1804	12'	4	1.5'	150'
61-70 / 5%-<10%	1804	9'	3	1.5'	200'
61-70 / 5%-<10%	1804	6	2	1.5'	301'
61-70 / 10%-15%	1883	12'	4	1.5'	157'
61-70 / 10%-15%	1883	9'	3	1.5'	209'
71-80 / 0%-<5%	1677	12'	4	3'	140'
71-80 / 0%-<5%	1677	9'	3	3'	186'
71-80 / 0%-<5%	1677	6'	2	3'	280'
71-80 / 5-10%	1929	12'	4	1.5'	161'
71-80 / 5%-10%	1929	9'	3	1.5'	214'
71-80 / 5%-10%	1929	6'	2	1.5'	322'
81-90 / 0%-<5%	1805	9'	3	3'	201'
81-90 / 0%-<5%	1805	6'	2	3'	301'
81-90 / 5%-10%	2076	9'	3	1.5'	231'
81-90 / 5%-10%	2076	6'	2	1.5'	346'

### Additional bedroom

Perc. Rate/Slope	Sand Bed Area (sq. ft.)	Sand Bed Width	Number of Lines	Ctr. to Ctr. Spacing	Min. Bed Length
61-70 / 0%-<5%	261	12'	4	3'	22'
61-70 / 0%-<5%	261	9'	3	3'	29'
61-70 / 0%-<5%	261	6'	2	3'	44'
61-70 / 5%-<10%	300	12'	4	1.5'	25'
61-70 / 5%-<10%	300	9'	3	1.5'	33'
61-70 / 5%-<10%	300	6	2	1.5'	50'
61-70 / 10%-15%	313	12'	4	1.5'	26'
61-70 / 10%-15%	313	9'	3	1.5'	35'
71-80 / 0%-<5%	280	12'	4	3'	24'
71-80 / 0%-<5%	280	9'	3	3'	31'
71-80 / 0%-<5%	280	6'	2	3'	47'
71-80 / 5-10%	322	12'	4	1.5'	27'
71-80 / 5%-10%	322	9'	3	1.5'	36'
71-80 / 5%-10%	322	6'	2	1.5'	54'
81-90 / 0%-<5%	301	9'	3	3'	34'
81-90 / 0%-<5%	301	6'	2	3'	50'
81-90 / 5%-10%	346	9'	3	1.5'	39'
81-90 / 5%-10%	346	6'	2	1.5'	58'

Continued

## Sizing Tables (percolation rates 61-90 min/inch), Continued

Commercial  
(per 100 GPD)

Perc. Rate/Slope	Sand Bed Area (sq. ft.)	Sand Bed Width	Number of Lines	Ctr. to Ctr. Spacing	Min. Bed Length
61-70 / 0%-<5%	261	12'	4	3'	22'
61-70 / 0%-<5%	261	9'	3	3'	29'
61-70 / 0%-<5%	261	6'	2	3'	44'
61-70 / 5%-<10%	300	12'	4	1.5'	25'
61-70 / 5%-<10%	300	9'	3	1.5'	33'
61-70 / 5%-<10%	300	6'	2	1.5'	50'
61-70 / 10%-15%	313	12'	4	1.5'	26'
61-70 / 10%-15%	313	9'	3	1.5'	35'
71-80 / 0%-<5%	280	12'	4	3'	24'
71-80 / 0%-<5%	280	9'	3	3'	31'
71-80 / 0%-<5%	280	6'	2	3'	47'
71-80 / 5-10%	322	12'	4	1.5'	27'
71-80 / 5%-10%	322	9'	3	1.5'	36'
71-80 / 5%-10%	322	6'	2	1.5'	54'
81-90 / 0%-<5%	301	9'	3	3'	34'
81-90 / 0%-<5%	301	6'	2	3'	50'
81-90 / 5%-10%	346	9'	3	1.5'	39'
81-90 / 5%-10%	346	6'	2	1.5'	58'

# Level Bed Diagrams (percolation rates 61-90 min/inch)

## Introduction

Level beds for percolation rates 61-90 min/inch installations are designed in 12', 9', or 6' widths. Here are three diagrams.

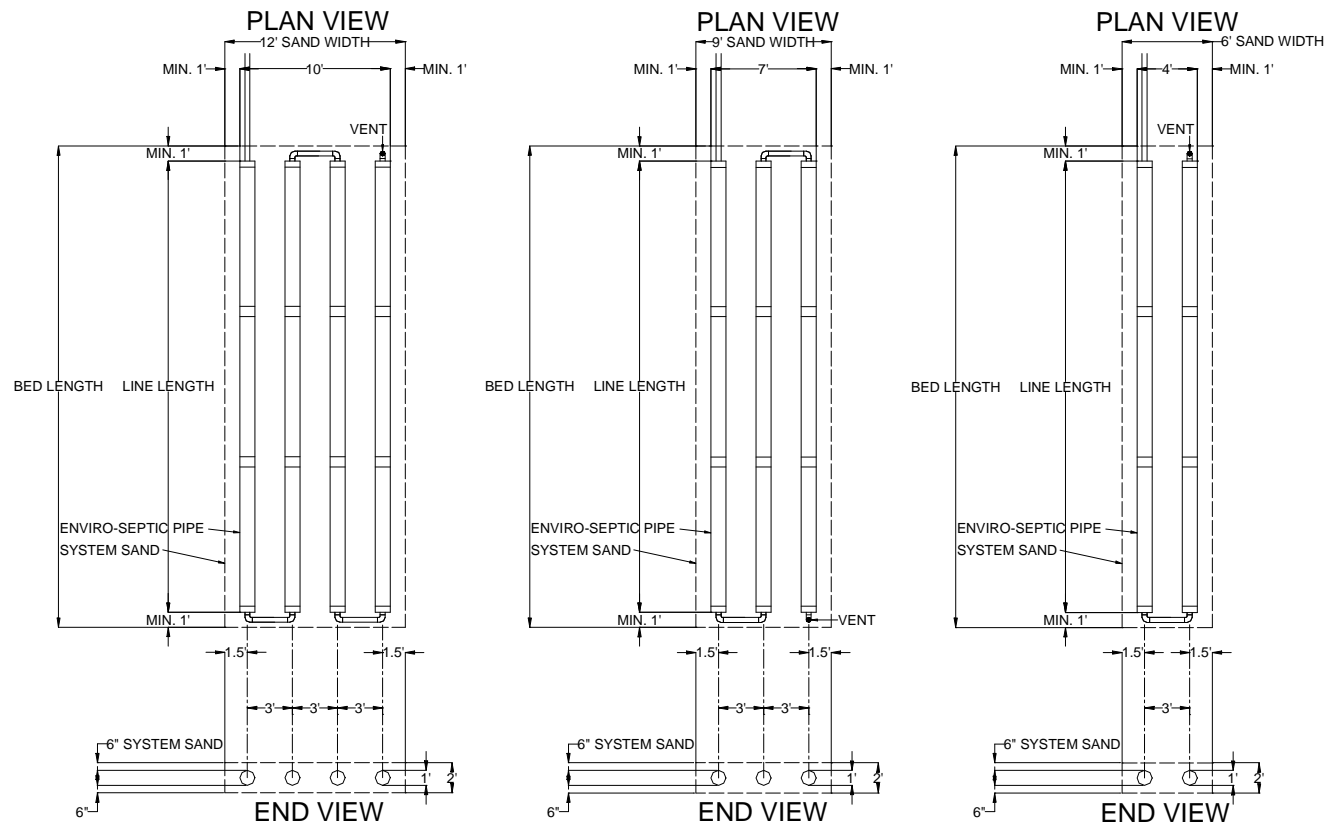

**12' WIDE BED**

**9' WIDE BED**

**6' WIDE BED**

ENVIRO-SEPTIC PIPE CONSTANT 3.0 FEET ON CENTER AT <5% SLOPE IN RESTRICTIVE SOILS  
 NOTE: SYSTEM MUST ALWAYS INLET TO THE HIGHEST PIPE



## Appendix A - System Installation Form

For each new or replacement installation, Massachusetts installers of Enviro-Septic® systems must complete and fax or mail a copy of this form to the local approving authority and to:

Presby Environmental, Inc.  
143 Airport Road  
Whitefield, NH 03598  
Fax: (603) 837-9864

Installer's Name:		
Company Name:		
Street Address:		
City:	State:	Zip:
Property Owner:		
Site Street Address:		
City:	State:	Zip:
System Type ( <i>circle one</i> ): General Use or Remedial Use	Design Flow:	
Installation Date:	System Startup Date:	
Permit Number:		
Comments:		

This form may also be completed online at  
[presbyenvironmental.com/state\\_approvals/massachusetts/system installation form](http://presbyenvironmental.com/state_approvals/massachusetts/system_installation_form)

**Appendix B**  
**Enviro-Septic® Wastewater Treatment System Technology Checklist**

---

**Purpose** This technology checklist is to be completed by an operator trained by Presby Environmental, Inc., to inspect Enviro-Septic® wastewater treatment systems.

Note: The Department's technology approval requires all Enviro-Septic® systems to be inspected annually.

---

**Submit copies to the local authority and the DEP** A completed copy of this checklist and the DEP Approved Inspection and O&M Form for Title 5 I/A Treatment and Disposal Systems must be submitted to the local approving authority and the Department. Copies of the inspection forms shall be submitted by January 30<sup>th</sup> for remedial systems inspected during the prior year and by September 31<sup>st</sup> for General use systems.

Any required sampling and test results should accompany this completed checklist.

---

**DEP address** Mail a copy of this checklist to  
  
Department of Environmental Protection  
Title 5 I/A Program  
One Winter Street, 6<sup>th</sup> Floor  
Boston, Massachusetts 02108

---

1. Facility Owner: \_\_\_\_\_
2. Facility Address: \_\_\_\_\_
3. Installation Date: \_\_\_\_\_ Previous Inspection Date: \_\_\_\_\_
4. Date of Inspection: \_\_\_\_\_
5. Residential Number of Bedrooms: \_\_\_\_\_ /Commercial Design Flow \_\_\_\_\_ GPD
6. Inspection Port Location(s): \_\_\_\_\_
- \_\_\_\_\_
7. Other (Explain): \_\_\_\_\_
- \_\_\_\_\_

**Inspection data (Complete all fields)**

8. Is daily flow within the system design flow?  Yes  No If no, explain:  
\_\_\_\_\_
  9. Does the owner verify the system use as described above?  Yes  No  
If no, explain: \_\_\_\_\_
- 

Over

**Enviro-Septic® Wastewater Treatment System Technology Checklist, page 2**

10. Septic tank last inspection date: \_\_\_\_\_ Inspected by: \_\_\_\_\_
11. Septic tank last pumped date: \_\_\_\_\_ Is pumping recommended?  Yes  No
12. Condition of the soil absorption system: (wet/dry/firm/soft/vegetative/other) \_\_\_\_\_
- 
13. Is there evidence of storm water flows or erosion over the septic system?:  Yes  No  
If yes, explain: \_\_\_\_\_
14. Is there evidence of soil slump or compaction by traffic or other means in the vicinity of the soil absorption system?:  Yes  No If yes, describe: \_\_\_\_\_
- 
15. Is effluent visible through the inspection port?  Yes  No If yes, describe the condition and the fluid level: \_\_\_\_\_
- 
16. Are solids visible through the inspection port?:  Yes  No If yes, describe the condition and depth of solids: \_\_\_\_\_
- 
17. Is there evidence of surcharging or effluent ponding in the D-Box?:  Yes  No  
If yes, describe and measure: \_\_\_\_\_
- 
18. Are the system vents in place?:  Yes  No If no, describe: \_\_\_\_\_
- 
19. Describe any other pertinent issues: \_\_\_\_\_
- 

**System Pump Inspection data (If applicable)**

20. Pump Chamber?:  Yes  No Condition: \_\_\_\_\_
21. Pumps Inspected: ?  Yes  No Number of Pumps: \_\_\_\_\_
22. Condition of Pumps: \_\_\_\_\_
23. System Alarms:  Yes  No N/A
24. Condition of Alarms: \_\_\_\_\_
25. Date of Last Alarm Test: \_\_\_\_\_

Inspected by: \_\_\_\_\_  
Date: \_\_\_\_\_  
Time: \_\_\_\_\_  
Signature of Inspector: \_\_\_\_\_

I certify that by signing above: I have inspected the sewage treatment and disposal system at the address above, have completed this report, and the information reported is true, accurate, and complete as of the time of the inspection.



# DEP Approved Inspection and O&M Form for Title 5 I/A Treatment and Disposal Systems

(Eljen, Enviro-Septic, RUCK, Geoflow)

## A. Installation

**Important:** When filling out forms on the computer, use only the tab key to move your cursor - do not use the return key.



Owner \_\_\_\_\_

Facility Street Address \_\_\_\_\_

City \_\_\_\_\_ Zip \_\_\_\_\_

Mailing address of owner, if different:

Street Address/PO Box: \_\_\_\_\_

City \_\_\_\_\_ State \_\_\_\_\_ Zip \_\_\_\_\_

( ) - ext. \_\_\_\_\_  
Telephone Number

## B. Authorized Service Provider

O&M Firm \_\_\_\_\_

Street Address \_\_\_\_\_

City \_\_\_\_\_ State \_\_\_\_\_ Zip \_\_\_\_\_

( ) - ext. \_\_\_\_\_  
Telephone Number

Operator Name \_\_\_\_\_ Technology Company/ Date of Training \_\_\_\_\_

## C. Facility/System Information

DEP ID \_\_\_\_\_ Manufacturer ID \_\_\_\_\_ Model Number \_\_\_\_\_

Installation Date \_\_\_\_\_ Start of Operation \_\_\_\_\_

Approval Type:  General  Provisional  Piloting  Remedial

Seasonal Residence – used less than 6 mo./year:  Yes  No

## D. Operating Information

Inspection Date \_\_\_\_\_ Previous Inspection Date \_\_\_\_\_



# DEP Approved Inspection and O&M Form for Title 5 I/A Treatment and Disposal Systems (Eljen, Enviro-Septic, RUCK, Geoflow)

Sludge Depth (to be checked yearly) \_\_\_\_\_ Pumping Recommended  Yes  No

## E. Field Testing – not required for standard inspection of Eljen, Enviro-Septic or RUCK

Field Inspection:

Color:  gray  brown  clear  turbid  
 Other (specify): \_\_\_\_\_

Odor:  musty  earthy  moldy  offensive  turbid

Effluent Solids:  no  some

pH  $\frac{\text{SU}}{6 \text{ to } 9}$  DO  $\frac{\text{mg/L}}{2 \text{ or greater}}$  Turbidity  $\frac{\text{NTU}}{40 \text{ or less}}$

Should a Remedial or General Use system fail the Field Testing, effluent samples shall be collected per Standard Methods and analyzed for BOD and TSS.

## F. Sampling Information – not required for standard inspection of Eljen or Enviro-Septic

Samples Taken:  Influent  Effluent

Commercial systems or systems with a design flow of 2000 gpd and greater, and General Use nitrogen reducing systems:

\_\_\_\_\_ gpd

Parameters sampled:  pH  BOD  CBOD  TSS  TN  Other (list below)

Other 1 \_\_\_\_\_ Other 2 \_\_\_\_\_ Other 3 \_\_\_\_\_

## G. Inspection and Maintenance

Description of any maintenance performed since previous inspection & during this inspection:

\_\_\_\_\_  
\_\_\_\_\_

Notes and Comments:

\_\_\_\_\_  
\_\_\_\_\_



Massachusetts Department of Environmental Protection  
Bureau of Resource Protection - Title 5

Appendix C

## DEP Approved Inspection and O&M Form for Title 5 I/A Treatment and Disposal Systems

(Eljen, Enviro-Septic, RUCK, Geoflow)

---

### H. Certification

I certify: I have inspected the sewage treatment and disposal system at the address above, have conducted any required Field Testing and/or sample collection in accordance with Standard Methods, have completed this report and the attached technology operation and maintenance checklist, and the information reported is true, accurate, and complete as of the time of the inspection. I have attended a training course for this System with the Technology Company and am listed by the Company as a trained inspector.

Operator Signature \_\_\_\_\_

Date \_\_\_\_\_

System owner must submit this report, technology O&M checklist, and any required sampling results to the local board of health and DEP as follows for each inspection performed:

**Remedial Use** – by January 31<sup>st</sup> of each year for the previous calendar year

**Piloting Use** - within 45 days of inspection date

**Provisional Use** – by March 31<sup>th</sup> of each year for the previous 12 months

**General Use** – by September 30<sup>th</sup> of each year for the previous 12 months

**Send to:**

Department of Environmental Protection  
Attention: Title 5 Program  
One Winter Street, 6<sup>th</sup> Floor  
Boston, MA 02108

# Appendix D

## Enviro-Septic<sup>®</sup> Wastewater Treatment System Operating Manual

---

**Introduction** Enviro-Septic<sup>®</sup> wastewater treatment systems are virtually maintenance free. However, an awareness of system abuse and simple easy maintenance will guarantee system longevity.

---

**System abuse conditions** The following conditions constitute system abuse.

- Liquid in high volume (excessive number of occupants, leaking fixtures, water beds, or whirlpool tubs, hot tubs, or water softeners if not specified in system design)
- Solids in high volume (excessive number of occupants, paper products, personal hygiene products, or garbage disposals or water softeners if not specified in system design)
- Antibiotic medicines in high concentrations
- Cleaning products in high concentrations
- Fertilizers or other caustic chemicals in any amount
- Petroleum products in any amount

---

**System maintenance** These simple procedures will guarantee system longevity.

- Inspect the septic tank at least once every two years under normal usage. Have the tank emptied when surface scum and bottom sludge occupy one-fourth or more of tank capacity.
- After pumping, inspect the septic tank for integrity to ensure than no groundwater flow is entering septic tank. Also check the integrity of the tank inlet and outlet baffles.
- Inspect the system for proper venting through either the roof or distribution box vent.

---

